

powermaster

INSTALLATION AND OWNER'S MANUAL

MODEL SG & DSG Slide Gate Operator UL 325 and UL 991 Listed



**WITH NEW NITRO BOARD
(INSTRUCTIONS INCLUDED)**

Serial #:

Date Installed:

Your Dealer:

READ THIS MANUAL CAREFULLY
BEFORE INSTALLATION OR USE.
SAVE THESE INSTRUCTIONS.



Table of Contents

Model SG/ D-SG Slide Gate Operator

Important Safety Information	4
Important Notice for Gate Operators Manufactured after 1/11/16	5
UL Installation and Safety Considerations.....	6
System Designer Safety Instructions.....	7
Installer Safety Instructions	8-9
End User Safety Warnings	10-11
Manual Operation	12
Safety Warnings	13

Installation & Setup Procedure

Before Installing Operator.....	14
Installation of Cement Pad.....	15-16
Attaching Drive Chain	17-19
Electrical Connections	20
Limit Adjustment	21-22
Left/Right Hand Conversion.....	23

Accessory Connections

Loop Detector Systems	24-26
Loop Installation (Standard Layout Chart).....	25
Cutting the Required Groove	25

Safety Device Connections

Non-contact Sensor Installation.....	26
--------------------------------------	----

PM Control Board

Indicator Descriptions	27
Terminal Descriptions	28
Operator Accessory Connections	29
Programming	30-38
Dual Gate Installations.....	39
Operation Indications.....	40
Error Codes and Trouble Shooting	41

Warranty	43
-----------------------	-----------

IMPORTANT!

FOR SLIDE GATE OPERATING SYSTEMS, SAFETY IS EVERYONE'S BUSINESS.

Automatic gate operators provide convenience and security to users. However, because these machines can produce high levels of force, it is important that all gate operator system designers, installers, and end users be aware of the potential hazards associated with improperly designed, installed, or maintained systems. Keep in mind that the gate operator is a component part of a total gate operating system.

The following information contains various safety precautions and warnings for the system designer, installer and end user. These instructions provide an overview of the importance of safe design, installation, and use.

Warnings are identified with the ▲ symbol. This symbol will identify some of the conditions that can result in serious injury or death. Take time to carefully read and follow these precautions and other important information provided to help ensure safe system design, installation and use.

▲ **WARNING:** Gate operators are only one part of a total gate operating system. It is the responsibility of purchaser, designer, and installer to ensure that the total system is safe for its intended use. All secondary entrapment safety devices must be **RECOGNIZED BY UL** to ensure the safety of the complete operating system.

▲ **WARNING:** This operator is only intended for installation on gates used for vehicular traffic. A separate pedestrian access opening shall be provided which is designed to promote pedestrian usage and shall be located such that persons will not come in contact with the vehicular gate during its entire path of travel.

IMPORTANT NOTICE FOR GATE OPERATORS MANUFACTURED AFTER JANUARY 11TH, 2016

All gate operators manufactured after January 11th, 2016 must have a monitored input for each direction. In order to satisfy this requirement all Powermaster Swing & Slide Gate Operators will have one monitored input for each direction: The close obstruction (C-OBS) terminal for the close direction and the open obstruction (O-OBS) terminal for the open direction. These terminals will look for, or “monitor” the presence of a 10k in-line resistor. If either terminal does not detect the presence of the monitored device the unit will function in constant contact for this direction.

E.g. The operator detects there is a monitored device on the C-OBS terminal but not the O-OBS terminal. The operator will function in momentary contact to close and constant pressure to open.

The UL 2016 devices for these units are as follows:

Device	Manufacturer	Description
Prime-Guard	Miller Edge	Monitored Photoeye
Reflecti-Guard	Miller Edge	Retroreflective Monitored Photoeye
IRB-MON	EMX	Monitored Photoeye
IRB-RET	EMX	Retroreflective Monitored Photoeye
The Solution	Miller Edge	Multiple Safety Devices

Any actions taken to circumvent this monitoring are in violation of the UL325, building code, and local laws.

UL INSTALLATION AND SAFETY CONSIDERATIONS

INSTALLATION CLASSES

CLASS I - RESIDENTIAL VEHICULAR GATE OPERATOR OPERATOR

A vehicular gate operator (or system) intended for use in a home of one to four single-family dwellings, or a garage or parking area associated therewith.

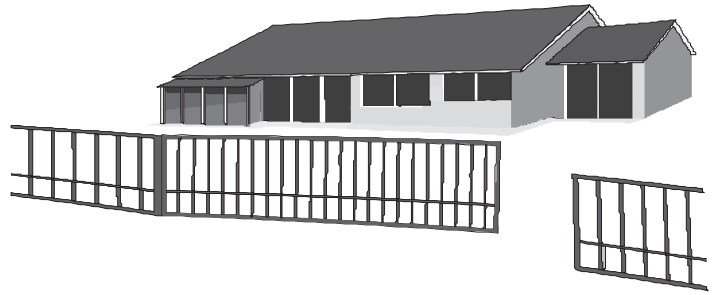

CLASS II – COMMERCIAL/GENERAL ACCESS VEHICULAR GATE OPERATOR

A vehicular gate operator (or system) intended for use in a commercial location or building such as a multifamily housing unit (five or more single family units), hotel, garages, retail store or other building servicing the general public.

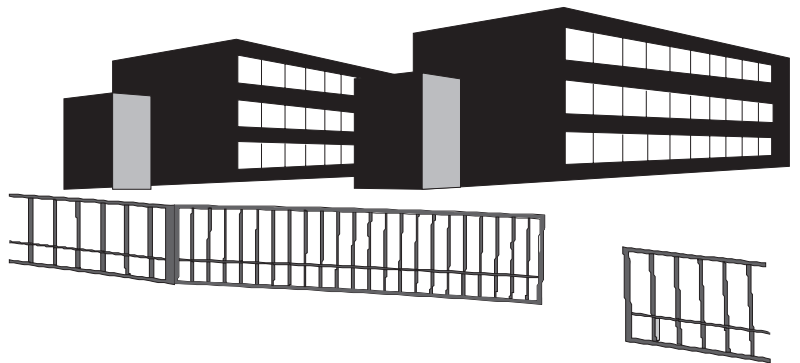

CLASS III - INDUSTRIAL/LIMITED ACCESS VEHICULAR GATE OPERATOR

A vehicular gate operator (or system) intended for use in an industrial location or building such as a factory or loading dock area or other locations not intended to service the general public.

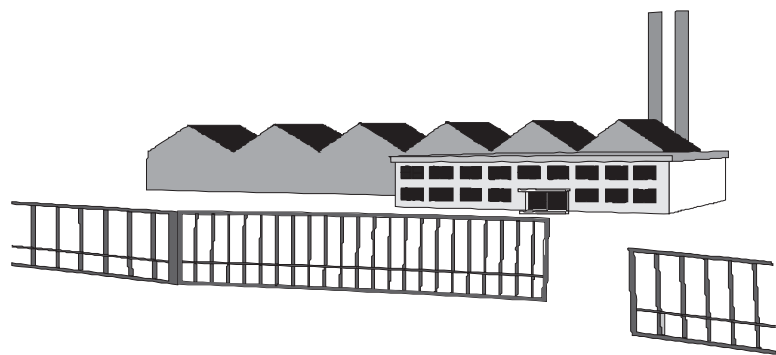

CLASS IV - RESTRICTED ACCESS VEHICULAR GATE OPERATOR

A vehicular gate operator (or system) intended for use in a guarded industrial location or building such as an airport area or other restricted access locations not servicing the general public, in which unauthorized access is prevented via supervision by security personnel.

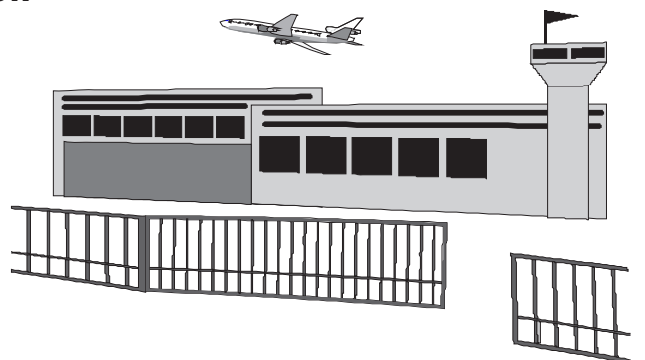

SYSTEM DESIGNER SAFETY INSTRUCTIONS

- ▲ 1. Familiarize yourself with the precautions and warnings for the installer. Users are relying on your design to provide a safe installation.
- ▲ 2. The operator is supplied with a primary obstruction sensing entrapment protection system. The installation must also have a secondary entrapment protection system installed, such as photoelectric sensors or an electric edge system.
- ▲ 3. When designing a system that will be entered from a highway or main thoroughfare, be sure the system is placed far enough away from the road to eliminate traffic backup. Distance from the road, size of the gate, usage levels, and gate cycle/speed must be considered to eliminate potential traffic hazards.
- ▲ 4. The majority of injuries from slide gate operator systems occur with Open Roller or Ornamental Grille Type Gates. We strongly recommend the use of roller guards. The illustrations and descriptive captions found on the following pages provide precautions to help eliminate injuries or fatalities. Familiarize yourself with them when designing the total system.
- ▲ 5. Design the gate system so a person cannot reach over, under, around, or through the gate to operate any controls. Never place controls on the gate operator itself.



INSTALLER SAFETY INSTRUCTIONS

BEFORE INSTALLATION

- ▲ 1. Check to see that the operator is proper for this type, size and class of gate and its frequency of use. If you are not sure, consult factory.
 - ▲ 2. Check to see that there are no structures adjacent to the area, which may pose a risk of entrapment when gate is opening or closing.
 - ▲ 3. You must ensure that the gate has been properly installed and works freely in both directions. Replace or service any worn or damaged gate hardware prior to installation. A freely moving gate will require less force to operate and enhance the performance of the operator as well as the safety devices used within the system.
 - ▲ 4. Install the gate operator on the inside of the property and/or fence line. **DO NOT** install an operator on the public side of the gate.
 - ▲ 5. Severe injury or death can result from entrapment by a gate. The operator is supplied with an obstruction sensing primary entrapment protection system. Additional safety equipment such as electric edges or photocell sensors must be installed to provide the required secondary entrapment protection system. For assistance in selecting the correct type of safety equipment, consult the factory.
 - ▲ 6. Review the operation of the unit and become familiar with the manual operation procedure and safety features of the system.
 - ▲ 7. You must install a pushbutton control or key switch to allow for normal operation of the gate if the automatic controls do not work. Locate the push button or key switch and small warning placard within sight of the gate in a secured area at least 10 feet or more from the gate and fence to keep users away from the moving gate and fence.
 - ▲ 8. Outdoor or easily accessed gate controls should be of the security type to prohibit unauthorized use. Please consult your local distributor concerning the types and specifications of available controls.
-

DURING INSTALLATION

- ▲ 1. Be aware of all moving parts and avoid close proximity to any pinch points.
- ▲ 2. Disconnect power at the control panel before making any electric service connections. Connection location for controls and safety equipment can be found on the wiring diagram, and in this manual.
- ▲ 3. Know how to operate the manual disconnect mechanism.
- ▲ 4. Adjust the open and close force adjustment on the control board, in each direction, to the minimum force required to operate the gate smoothly. **DO NOT increase the force adjustment setting to make up for rough spots in gate travel - FIX THE GATE INSTEAD!**

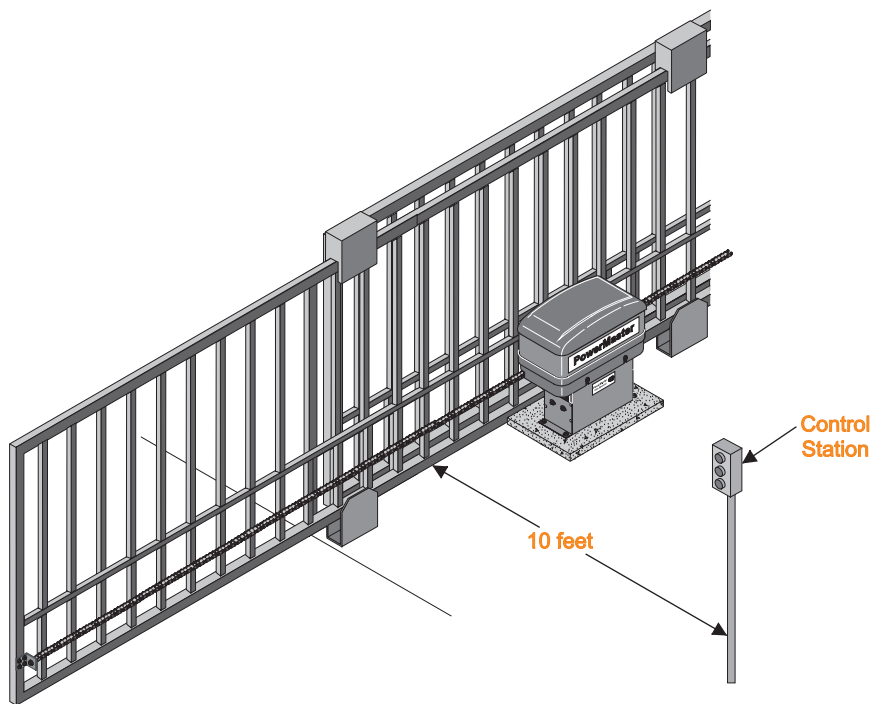

- ▲ 5. Locate the controls at least 10 feet from the moving gate so that the user can observe the gate operation, but is not able to come in contact with the gate while operating the controls.

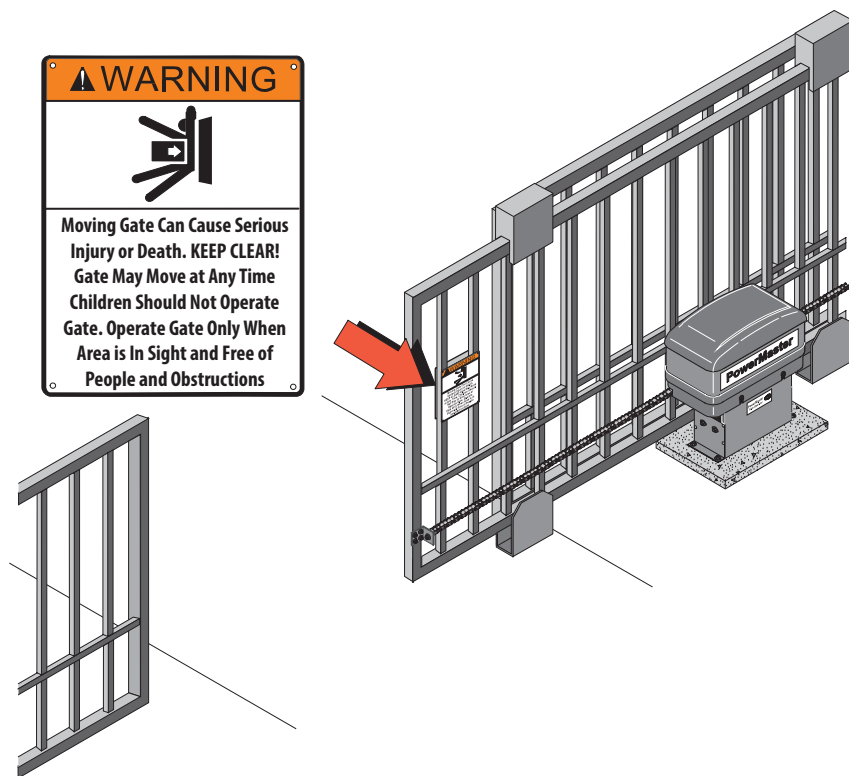

- ▲ 6. Attach large warning signs provided to each side of the gate or fence in the most conspicuous place. Mount control station and smaller warning placard together within sight of the gate opening.

AFTER INSTALLATION

- ▲ You are responsible for ensuring that the end user understands the basic operations and safety systems of the unit, **INCLUDING THE MANUAL OPERATION PROCEDURE.**
- ▲ Point out that the safety instructions in brochure are the responsibility of the end user, and then **LEAVE THIS MANUAL WITH THE END USER.**

END USER SAFETY WARNINGS

The manufacturer of the gate operator does not know what type of gate you have, or what type of automatic system is installed on your gate. Be sure you've been fully instructed on the sequence of operation for your specific gate system(s). Keep the gate properly maintained and have a qualified service person make repairs.

- ▲ 1. Be sure the following safety instructions are distributed to all persons authorized to use your gate.
- ▲ 2. **KEEP GATEWAY CLEAR (Front and Back) AT ALL TIMES.**
Your automatic gate is not for pedestrian use. No one should ever cross the path of the moving gate.
- ▲ 3. **DO NOT** allow children to play near your gate, or to operate the gate.
- ▲ 4. **DO NOT** operate your gate system unless you can see it when the gate moves.
- ▲ 5. Be sure a pushbutton or key switch has been installed for manual electric operation in the event your radio or card key does not work. Any mounted control station should be located a minimum of 10 feet from the gate so the gate cannot be reached through or touched. Any pushbutton located in a building should be installed within sight of the gate.
- ▲ 6. **DO NOT** operate any controls without watching the movement of the gate.

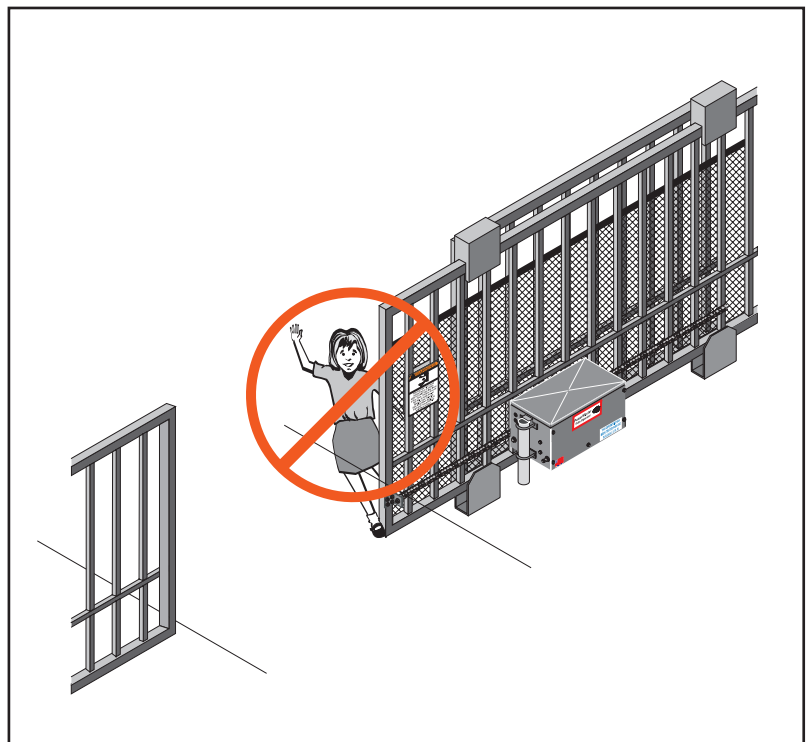

- ▲ 7. If your gate has open rollers, be sure roller guards have been purchased and installed.

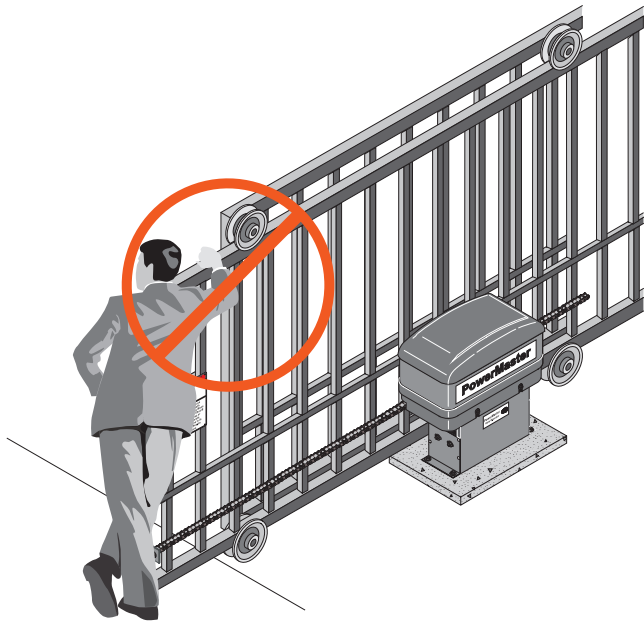

INCORRECT

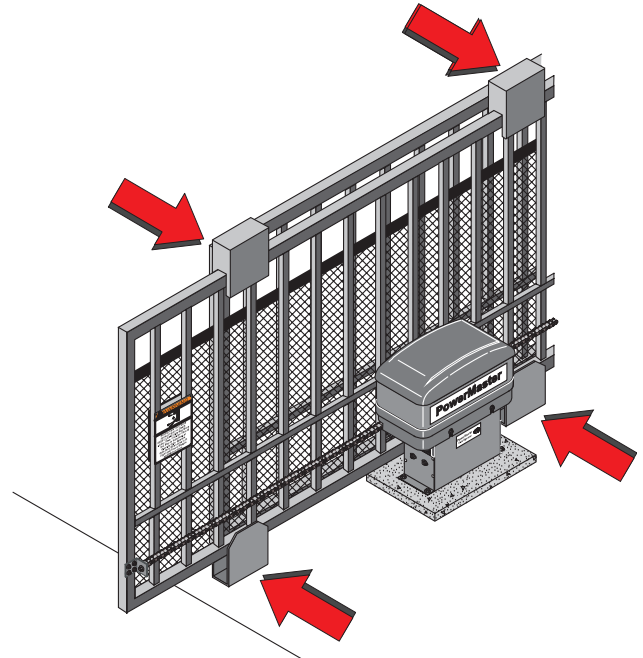

CORRECT

- ▲ 8. Your gate system is required to have a primary and a secondary entrapment safety system installed and maintained.
- ▲ 9. If your gate closes automatically, loop detectors should be installed to detect the presence of a vehicle.
- ▲ 10. DO NOT increase force adjustment to compensate for a damaged gate. The gate should always be maintained to operate manually as easily as possible to provide maximum protection.
- ▲ 11. Check all safety systems at least once per month for the correct force, speed and sensitivity. Gate must reverse when hitting a rigid object, or when a non-contact sensor is activated. **If these functions are observed to operate improperly, discontinue use and have it serviced immediately!**
- ▲ 12. You are responsible for ensuring that warning signs are installed and maintained on both sides of your gate.
- ▲ 13. To ensure safe operation of this equipment, you must read this safety manual and keep it for reference.

MANUAL DISCONNECT OPERATION

Your operator is equipped with a pad lockable emergency disconnect for manual operation. Be sure you have a key and understand how to operate this equipment. To disengage operator, move red disconnect lever to the left and latch it in place. See **Figure 1**.

WARNING: NEVER OPERATE THE MANUAL RELEASE WHEN THE GATE IS MOVING.

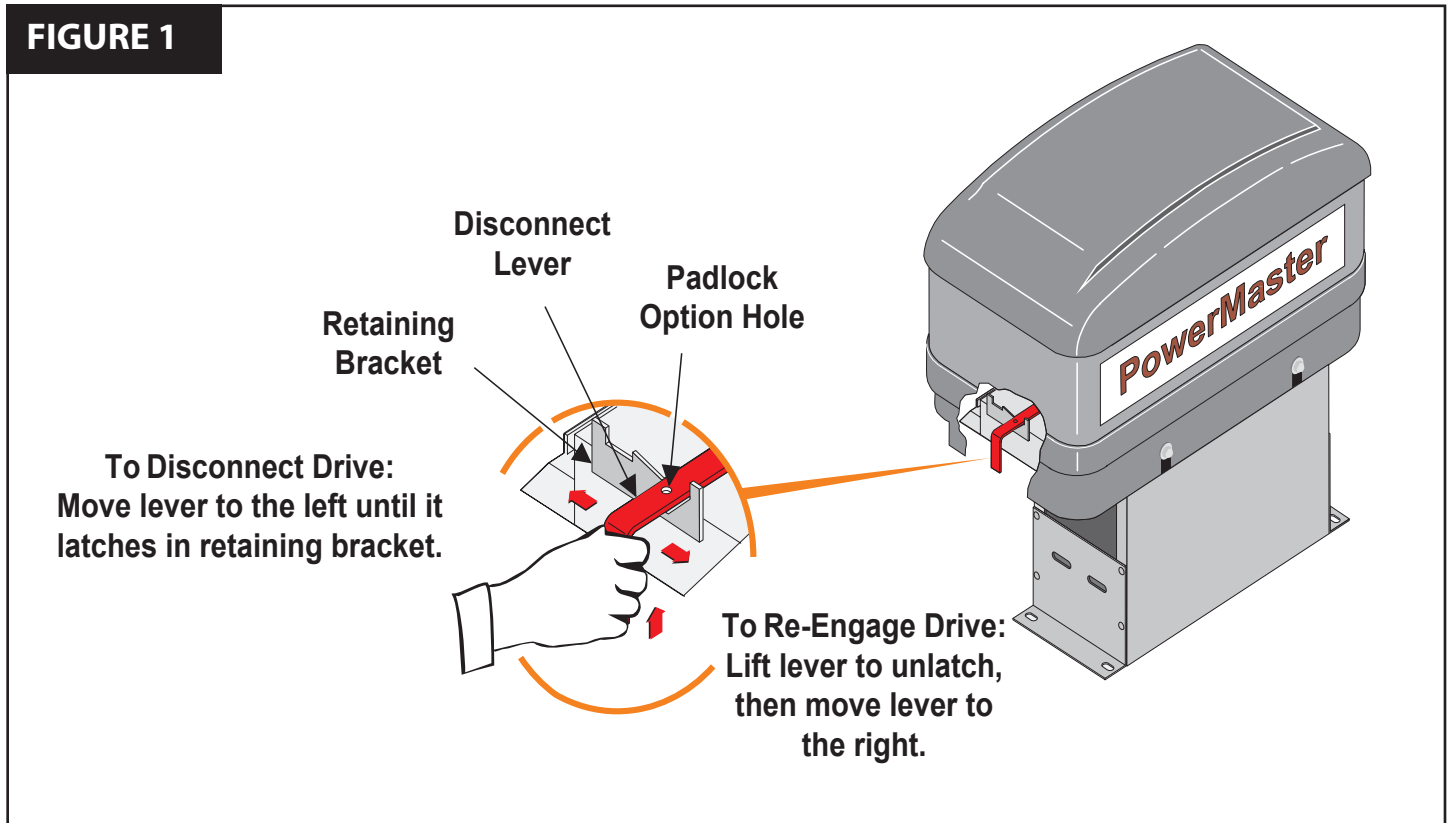

WARNING

NEVER ATTEMPT TO OPERATE THE MANUAL RELEASE WHEN THE GATE IS IN MOTION!

SAFETY WARNINGS FOR OPEN-ROLLER GATES AND ORNAMENTAL GRILLE-TYPE GATES



WARNING

INJURIES ASSOCIATED WITH AUTOMATIC GATES ARE MAINLY INCURRED WITH OPEN-ROLLER GATES AND ORNAMENTAL GRILLE TYPE GATES.

WARNING: INJURIES ASSOCIATED WITH AUTOMATIC GATES ARE MAINLY INCURRED WITH OPEN-ROLLER GATES AND ORNAMENTAL GRILLE-TYPE GATES.

OPEN-ROLLER GATES

Injuries occur when people get their hands caught between the top of the gate and the roller. This potential pinch point should be guarded whenever an automatic operator is installed. Roller Guards are available from various fence suppliers for refitting of these rollers.

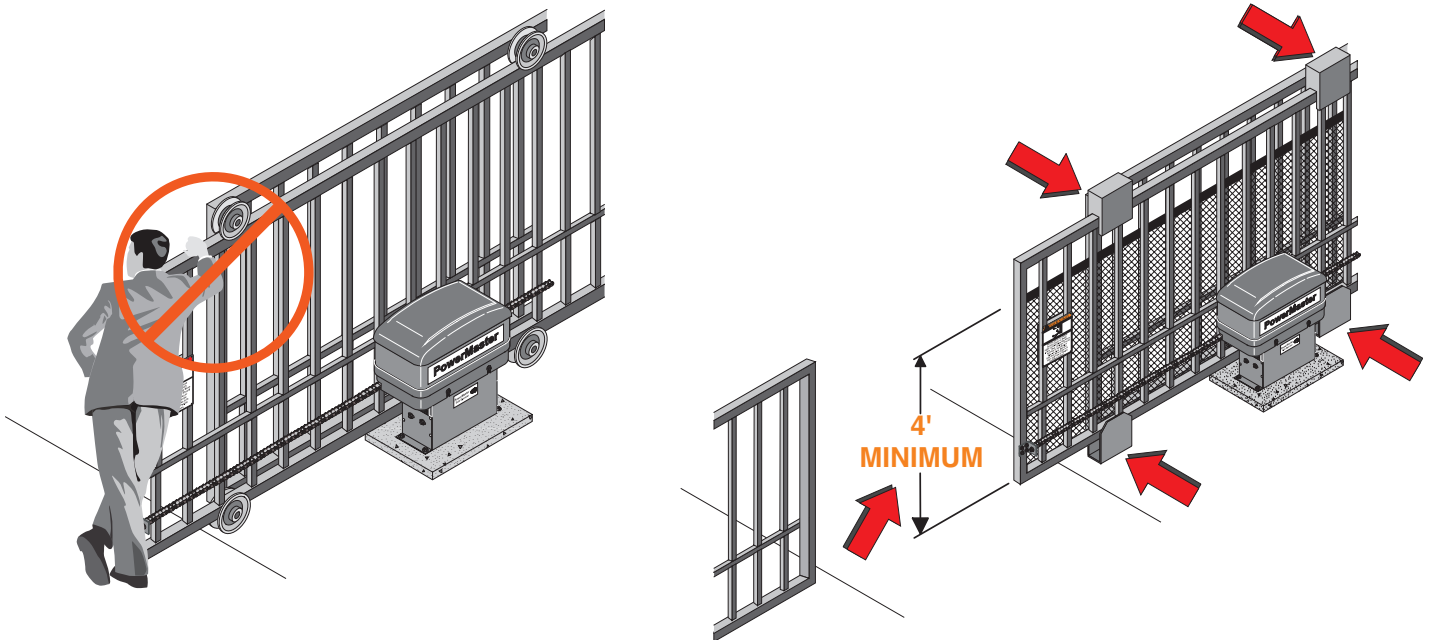

ORNAMENTAL GRILLE-TYPE GATES

Injuries occur when people put their arms through the openings in the grilles when the gate is operated. The person cannot retract his/her arm and it gets caught between the grille and the fence post or fence. The potential hazard must be guarded. It can be simply done by placing a screen mesh on the gate and fence in the area of the gate. The screen must be a minimum of 4 feet high from the bottom (unless the gate and fence are shorter) with openings that a 2-1/4 inch sphere cannot fit through. This will help to prevent access through openings when the gate travels.

INSTALLATION INSTRUCTIONS & SET-UP PROCEDURE



WARNING

DO NOT APPLY POWER UNTIL TOLD TO DO SO! RISK OF ELECTRICAL SHOCK OR INJURY MAY RESULT!

BEFORE INSTALLING OPERATOR

IMPORTANT: Operator should always be mounted inside the gate. Determine whether the installation is Left hand or Right hand by the direction the gate moves in order to open, when viewed from inside the fence.

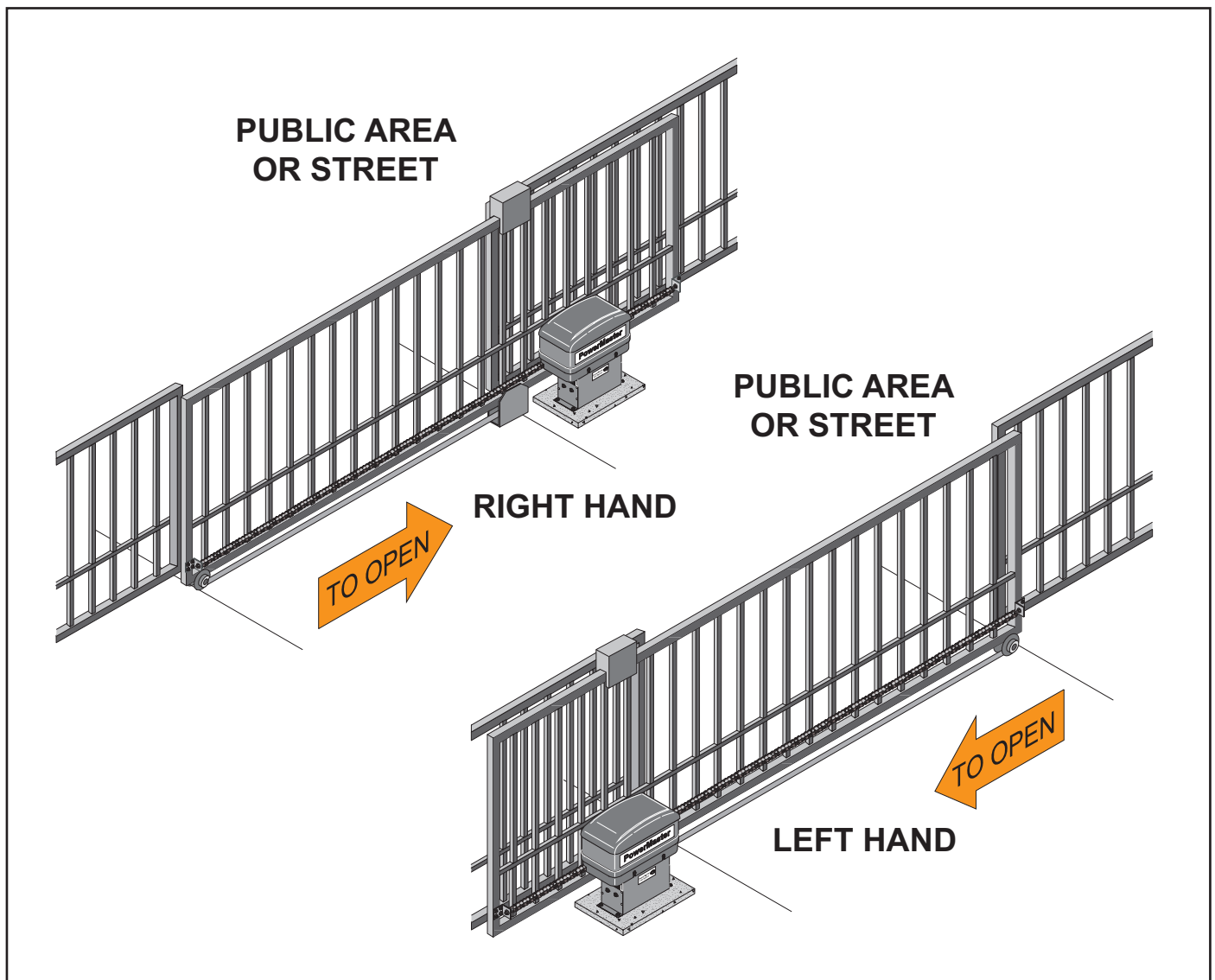

1. Gate must slide freely to fully opened and fully closed position.
2. Gate and/or extension must extend beyond the position of the operator when gate is in a fully closed position. The operator will be located as shown above, for left and right hand installation.

INSTALLATION OF CEMENT PAD

Lay out the cement pad as shown in **Figure 2**. Be sure top surface is level. Allow 2 days cure time before installing operator. Bolt pattern must be parallel to the gate.

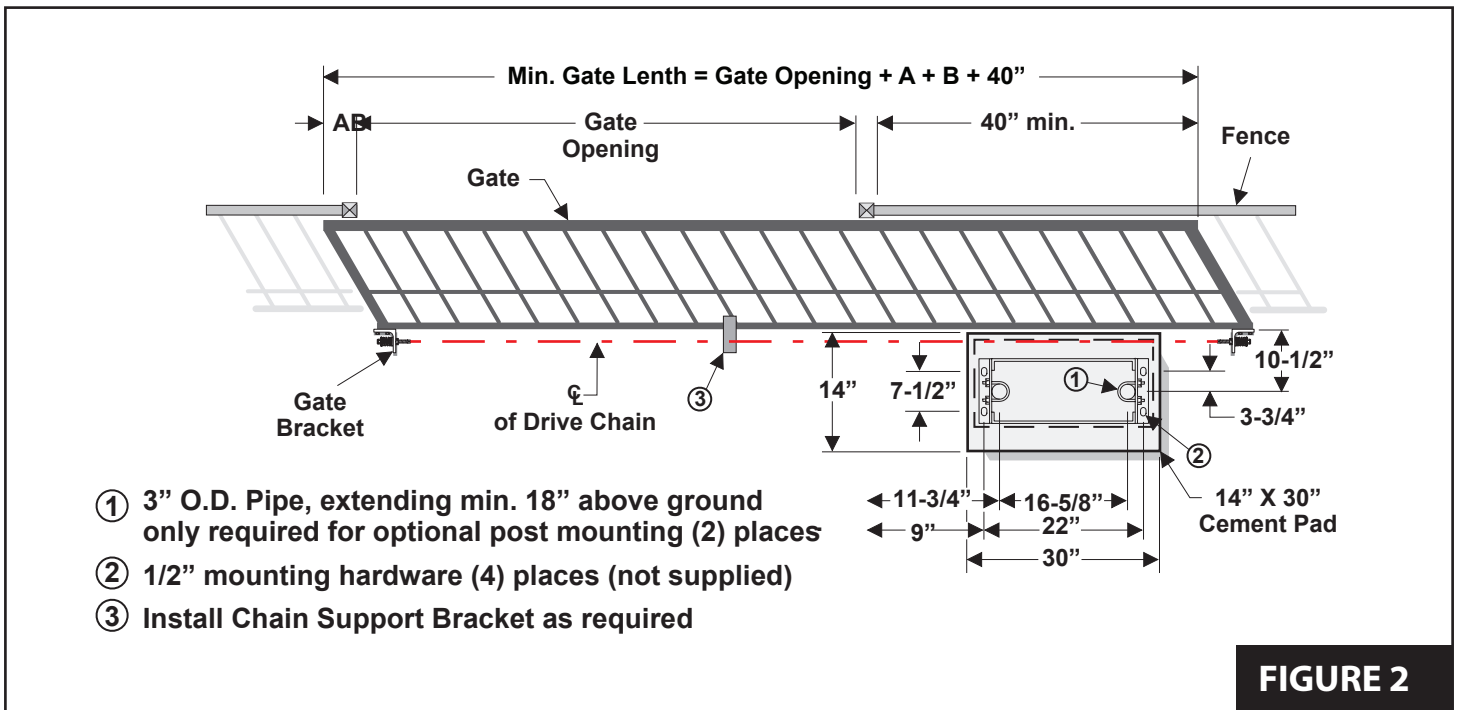

FIGURE 2

INSTALLATION TO PAD

1. Assemble stand and mount power head using carriage bolts. See **Figure 3**.

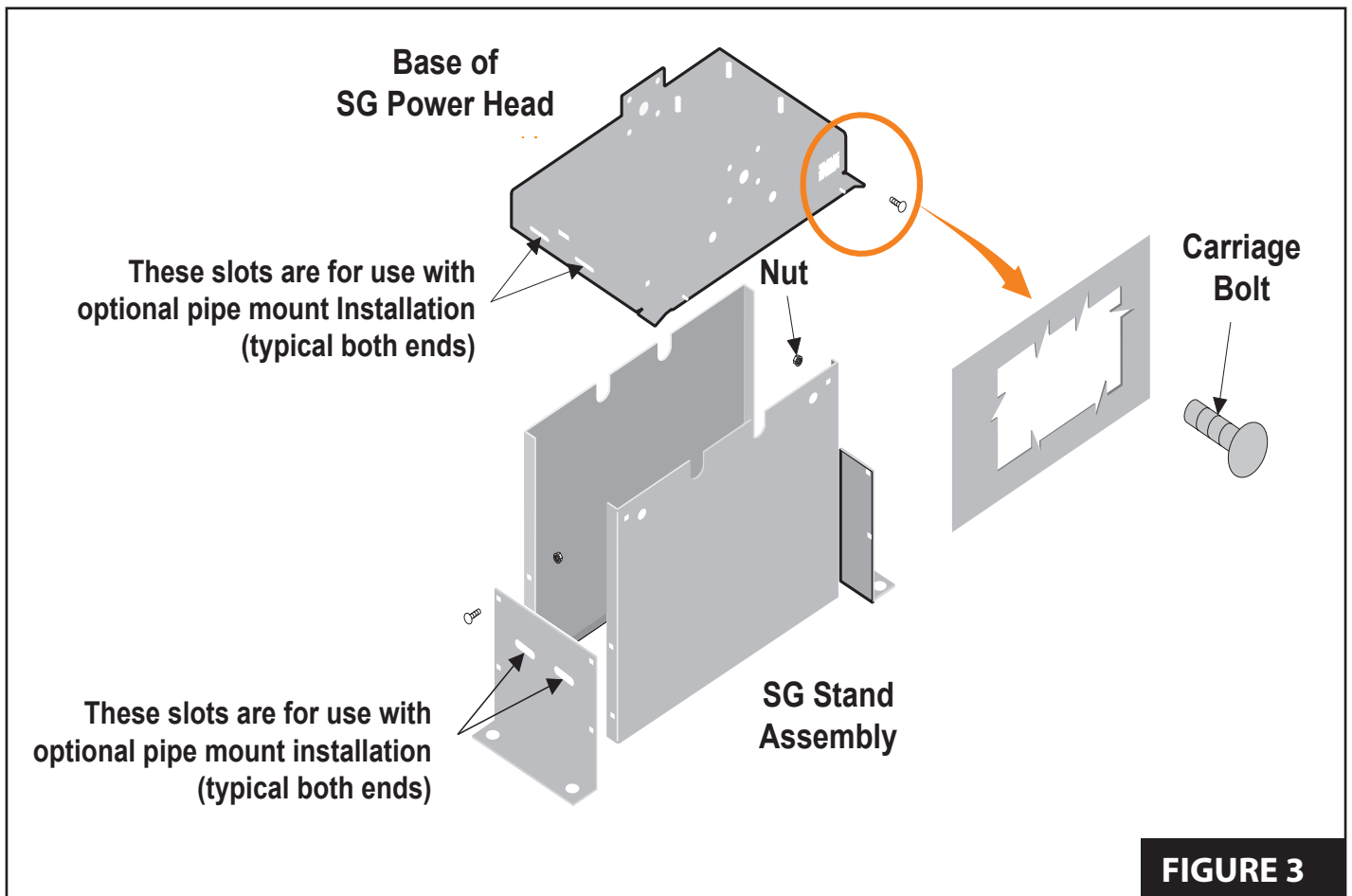

FIGURE 3

- Using 1/2" hardware (not supplied), bolt assembled unit to the pad, being sure to align operator parallel to the fence.

NOTE: Sprockets must face the fence.

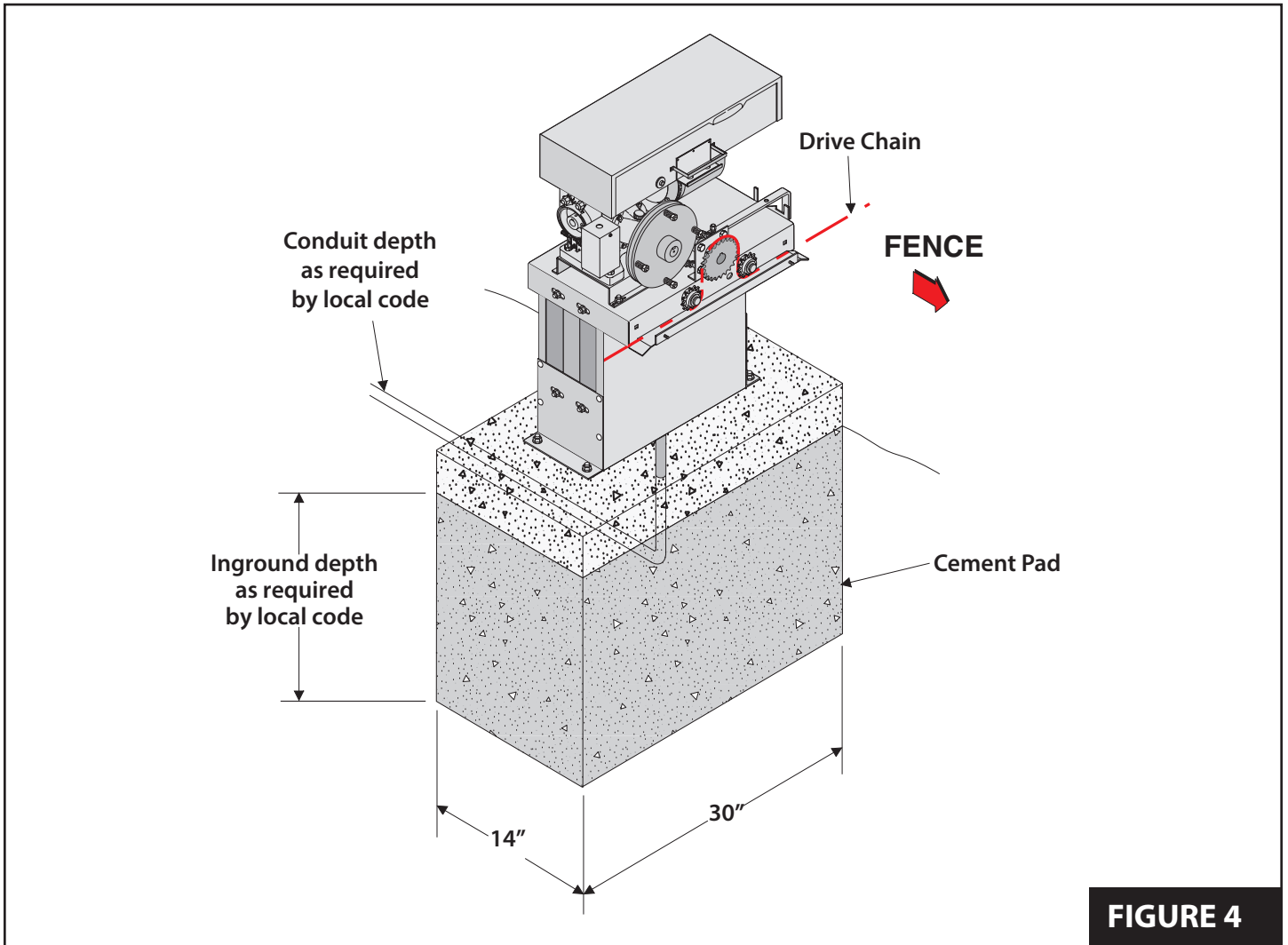
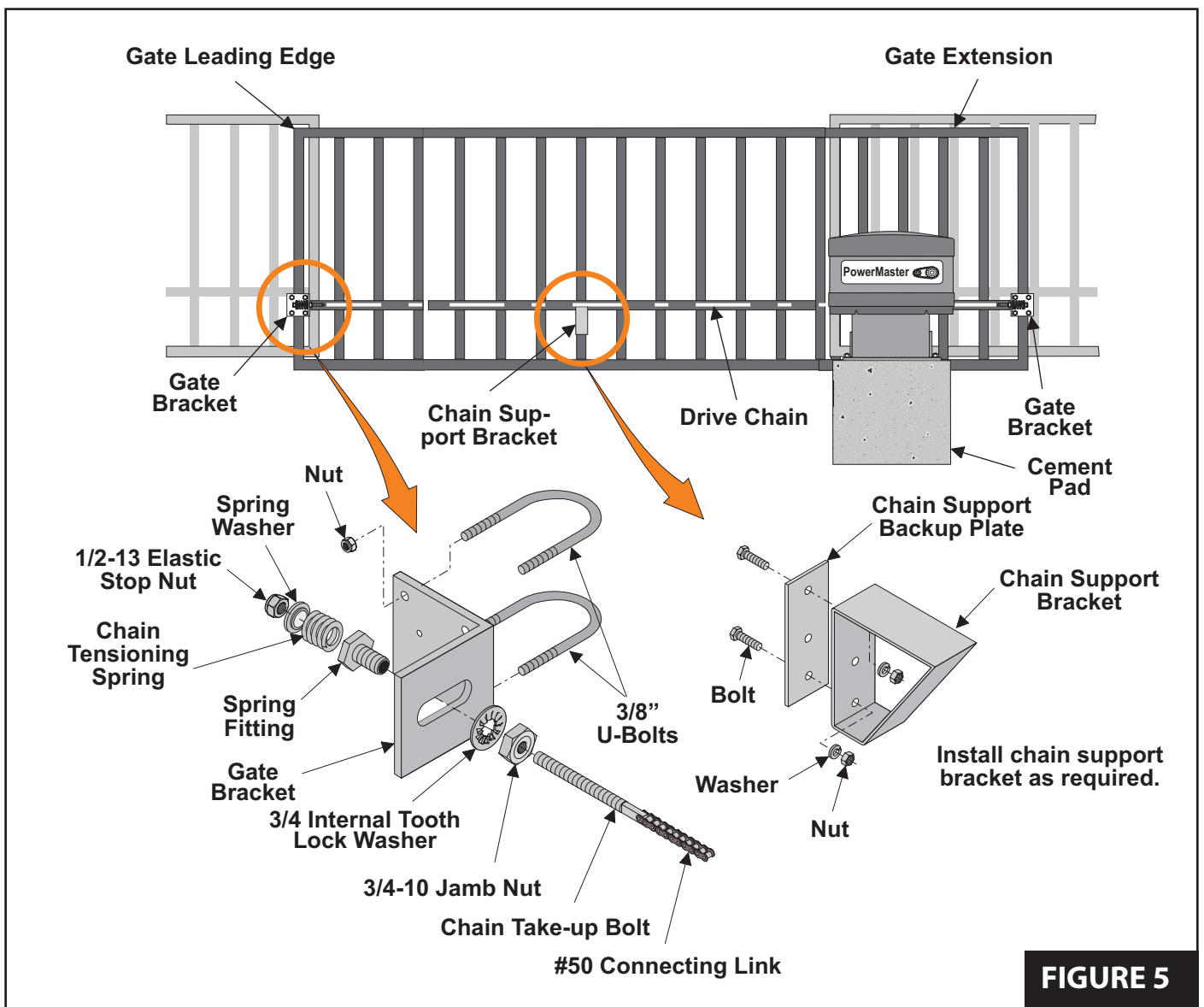

FIGURE 4

ATTACHING DRIVE CHAIN

1. Install gate brackets at each end of the gate with U-bolts provided. Do not fully tighten at this time.
2. Attach a chain take-up bolt to one end of the drive chain using a #50 connecting link.
3. Install spring fittings into gate brackets using 3/4" nuts and lock washers. DO NOT TIGHTEN.
4. Install chain take-up bolt (previously attached to the chain) into spring fitting in furthest gate bracket. Secure it in position with spring, spring washer, and 1/2" elastic stop nut.



5. Disengage operator by moving the red disconnect lever (Located on the operator base at the opposite end from the motor) to the disconnect position, and latch in place.

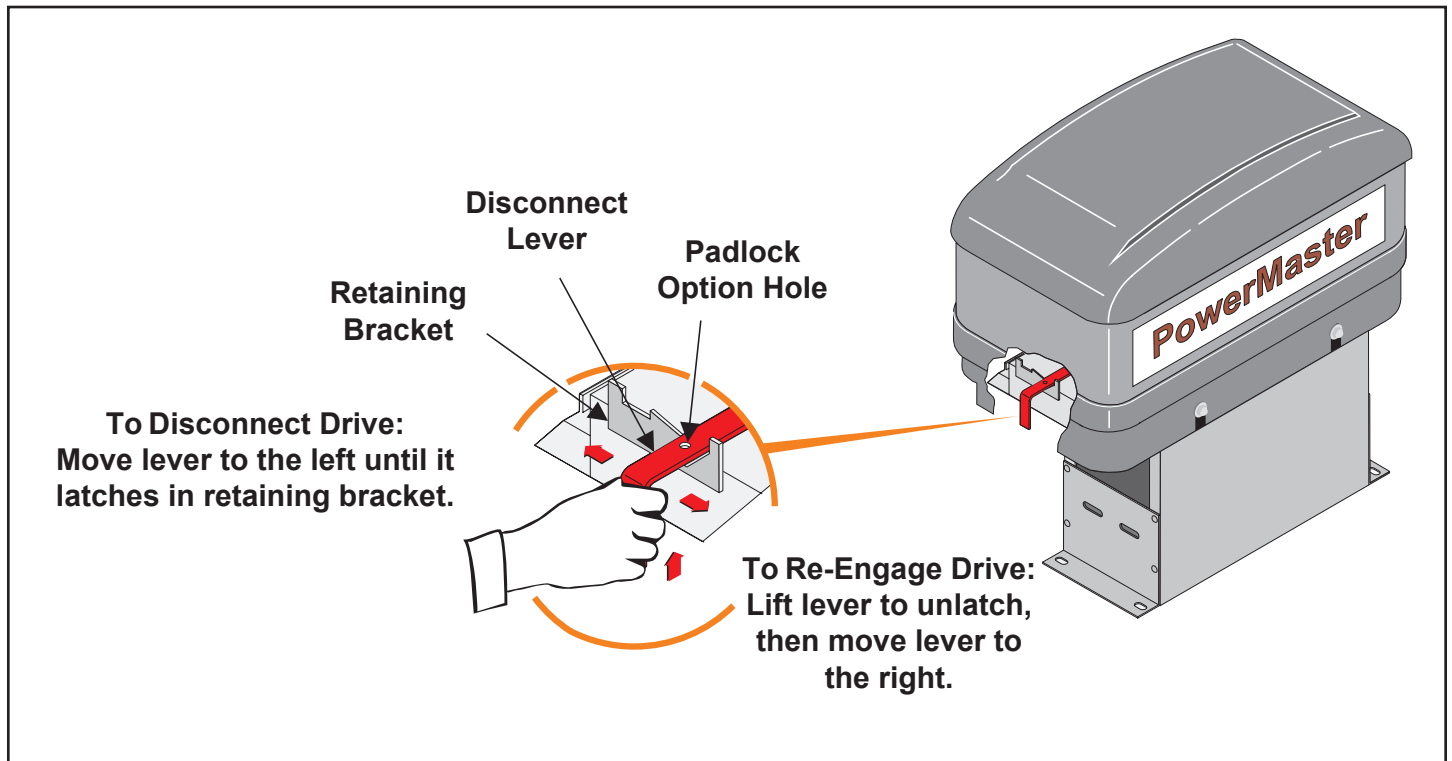

6. Thread free end of chain under first idler sprocket, up and over drive sprocket, then under the second idler sprocket. See **Figure 6**.

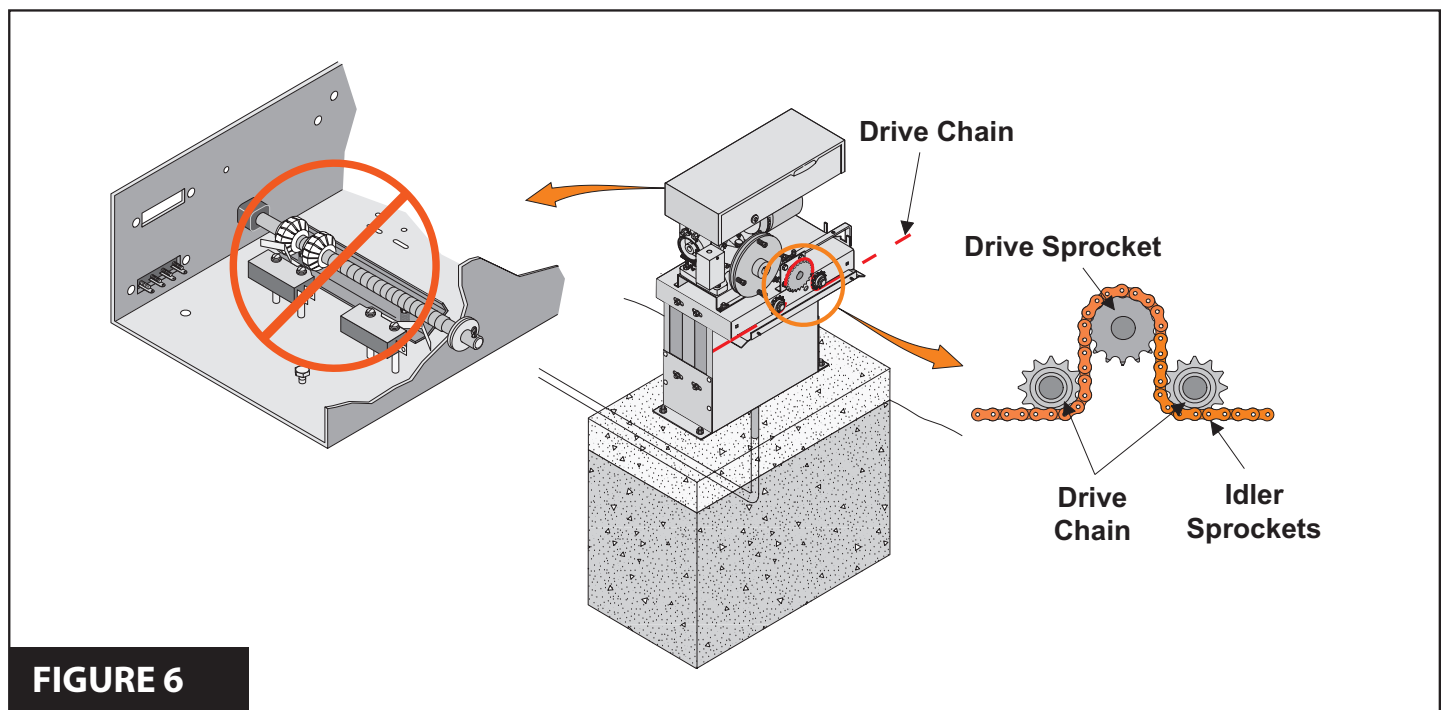

NOTE: When pulling chain through operator sprockets, the limit nuts in the electric box can be driven passed their normal position. Reset limit nuts as necessary to prevent them from being damaged during this procedure.

7. Pull the chain through to the opposite end of the gate. Cut the chain to the correct length, attach remaining chain take-up bolt and install in the gate bracket, as in Steps 2 through 4.
8. Adjust the gate bracket height at both ends of the gate to ensure the drive chain aligns with the operator idler sprockets.

9. Tighten the gate brackets securely and lock in position with the setscrews provided. See **Figure 7**.

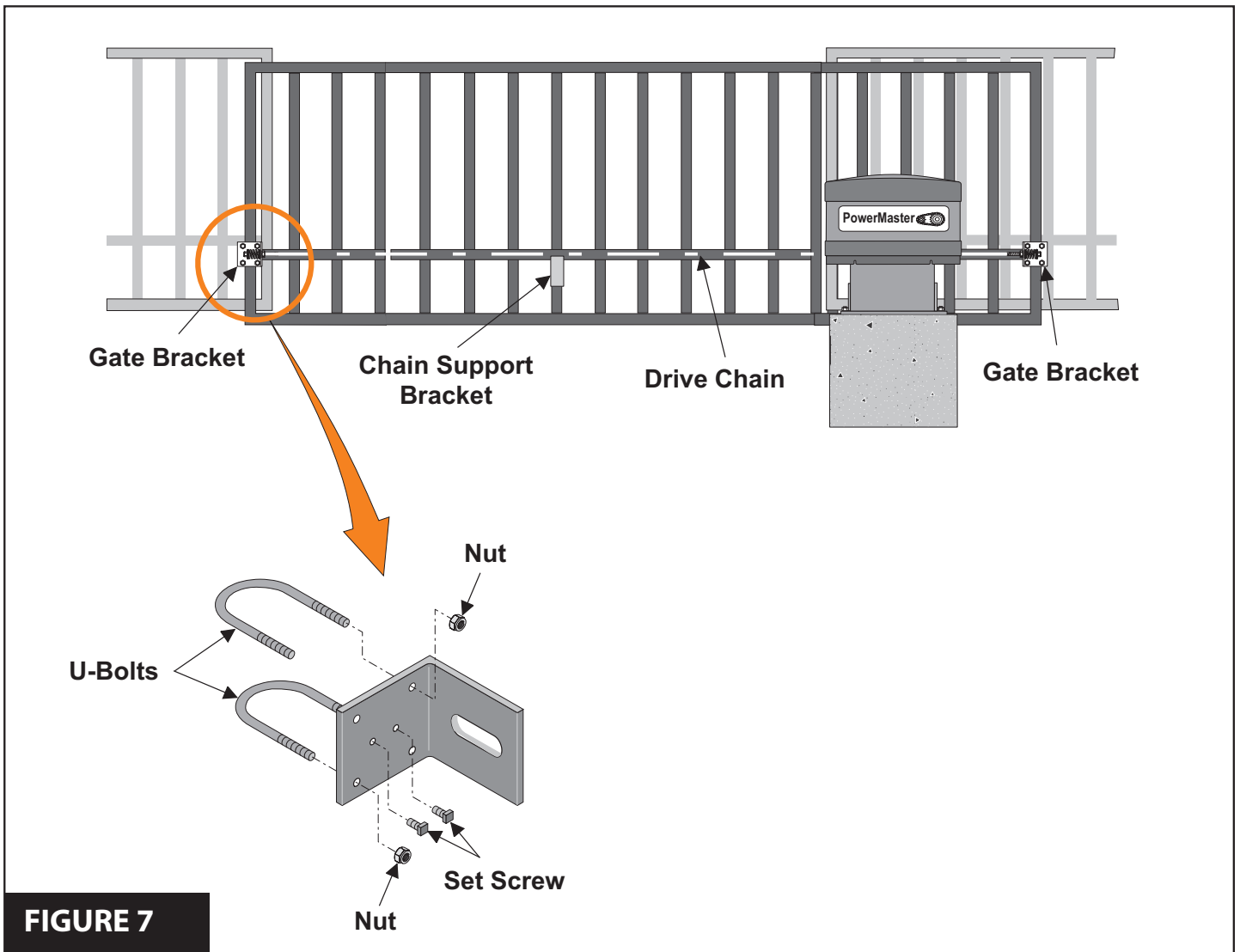

NOTE: By moving the gate manually to each end of its travel, chain alignment is simplified

10. Adjust chain tension so that the chain tension springs are reduced to a length within 1-7/8" and 1-3/4".

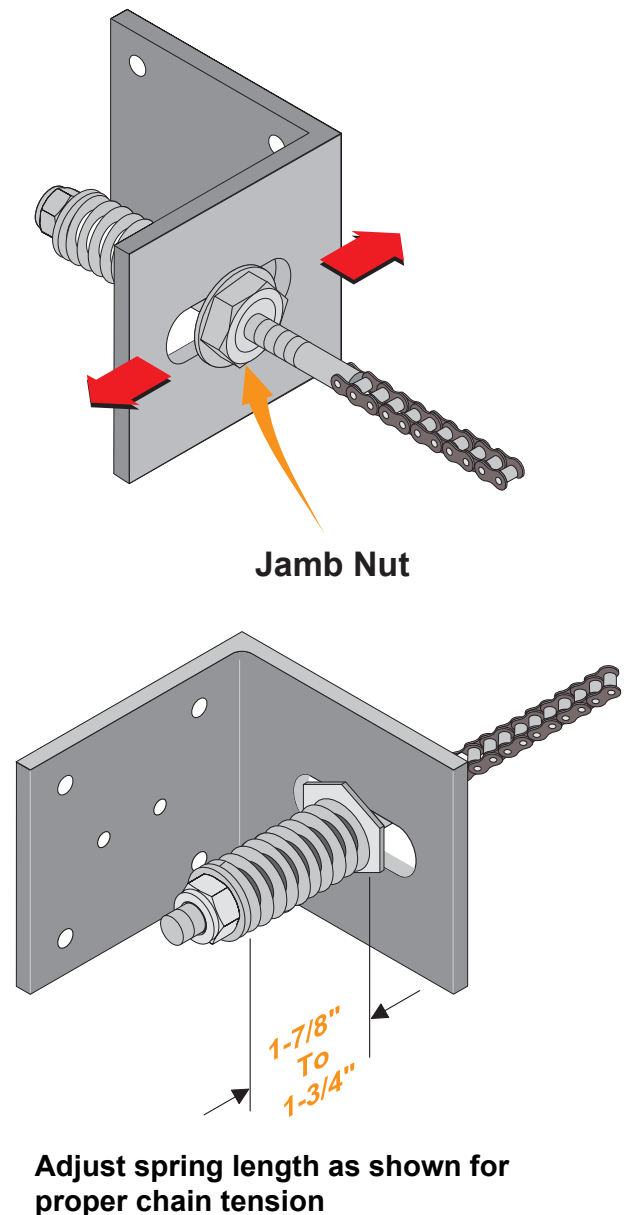

ELECTRICAL SET-UP AND CONNECTIONS

 WARNING	DO NOT APPLY POWER UNTIL TOLD TO DO SO! RISK OF ELECTRICAL SHOCK OR INJURY MAY RESULT!
--	---

CONNECTION OF INCOMING POWER

NOTE: Wiring to operator must use watertight materials in accordance with local electric code. See wire gauge/distance charts for proper sizing. Master/Slave installations should have SEPARATE power supply wiring or length of wire runs should be figured at half that shown on the chart. This unit must be grounded in accordance with N.E.C. and local codes.

NOTE: Before connecting the operator, use a voltmeter to determine that the electrical service is 115V. THIS OPERATOR CANNOT BE CONNECTED AT 230 VOLTS. Damage will result which is not covered under warranty.

NOTE: Before connecting the operator to an incoming power supply, use a voltmeter to determine that the electrical service is the same as that on the operator label. If the operator is connected to an incorrect power supply, damage will result, which is NOT covered by warranty.

- ▲ 1. Be sure both the power switches at the source and at the operator are OFF.
- ▲ 2. In the diagram below, find the supply power that matches your installation and connect as shown.

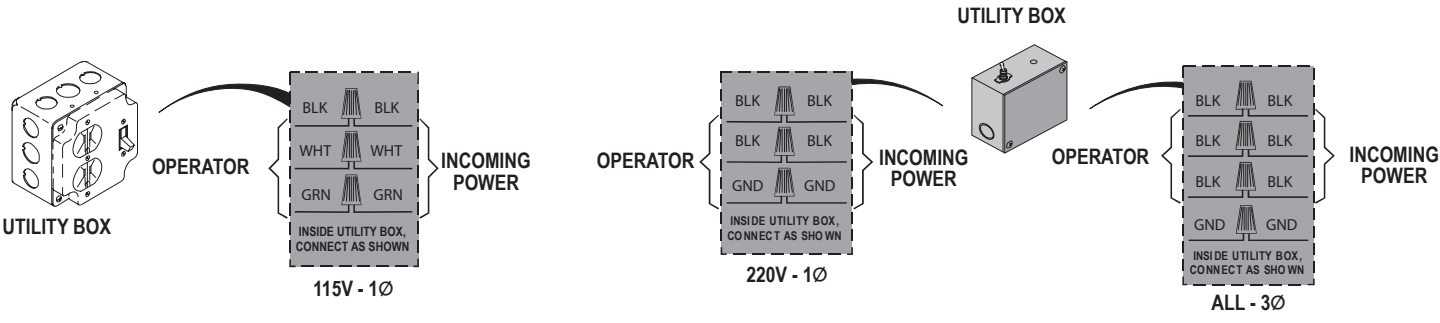

LOW VOLTAGE WIRE GAUGE/ DISTANCE CHART	
24 AWG:	Up to 150'
20 AWG:	150' - 200'
18 AWG:	250' - 1,500'
Control wiring should be run as twisted pairs. DO NOT run control wires in the same conduit as power wires, telephone wires, or loop detector leads.	

Line Voltage	HP	WIRE GAUGE				
		14 AWG	12 AWG	10 AWG	8 AWG	6 AWG
1 PH 115/ 208-230	1/2	150/350	250/400	400/500	500/700	650/1000
	3/4		150/250	250/400	400/600	500/850
	1			150/300	250/450	400/700
3 PH 208-230/ 440-480	1/2	450/2000	750/3000	1200/4300		
	3/4	350/1500	600/2400	900/3700	1100/4500	
	1	300/1200	450/1900	750/3000	900/4800	
	1-1/2	200/800	400/1500	500/2000	900/4800	

LIMIT ADJUSTMENT PROCEDURE



WARNING

TURN OFF INCOMING POWER AT OPERATOR POWER BOX BEFORE MAKING ANY ADJUSTMENTS!



WARNING

STAY CLEAR OF ALL MOVING PARTS AND ELECTRICAL COMPONENTS OF THE OPERATOR WHILE TESTING!

1. After the gate is mechanically installed, disengage operator drive with the manual disconnect lever. Move the gate to a midway position.

NOTE: When moving the gate with the operator disengaged, the limit nuts in the electric box can be driven passed their normal position. Reset the limit nuts as necessary by depressing the pressure plate and rotating the limit nuts until they are both positioned near the center of the limit shaft.

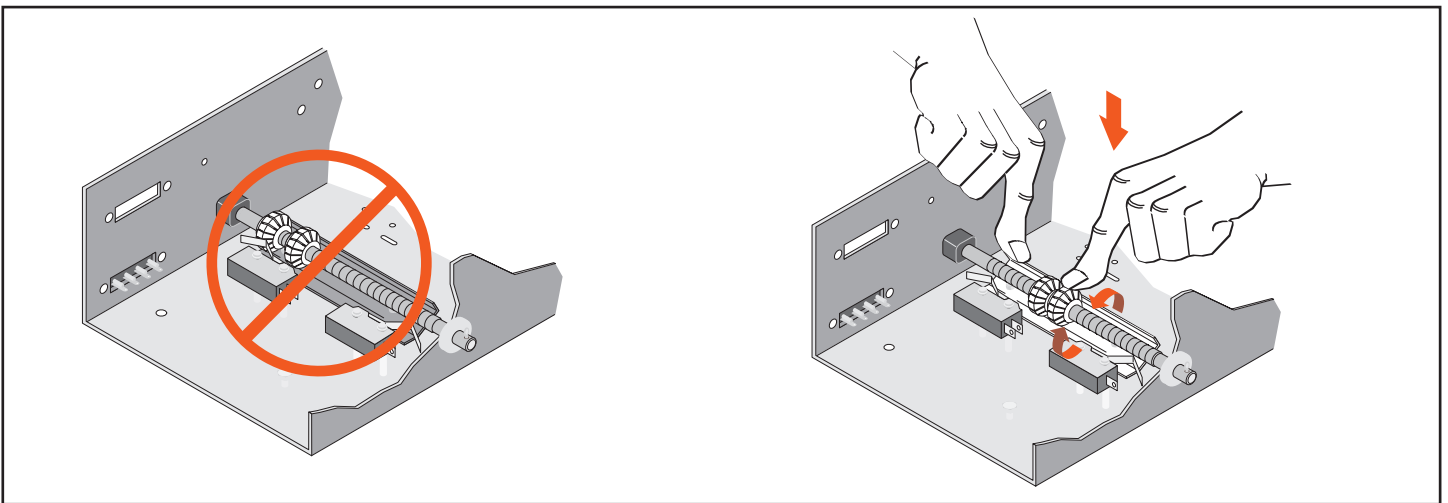

2. With the gate at mid travel, depress the pressure plate and set the grooved limit nuts approximately 1 inch from the limit switches on each side.
3. Open the gate electrically using the 3-button control station mounted.

▲WARNING: UNDER NO CIRCUMSTANCES SHOULD THE CONTROL STATION WIRING BE ALTERED IF THE ROTATION IS INCORRECT. TO DO SO WILL CAUSE SOME CONTROL FUNCTIONS TO BE INOPERATIVE AND MAY RESULT IN PERSONAL INJURY OR DAMAGE TO THE GATE AND/OR OPERATOR.

4. If the gate travels in the correct direction and stops on the open limit switch, proceed to Step 6.

NOTE: Open and Close limit switches are reversed for *Slide Left to Open* operation.

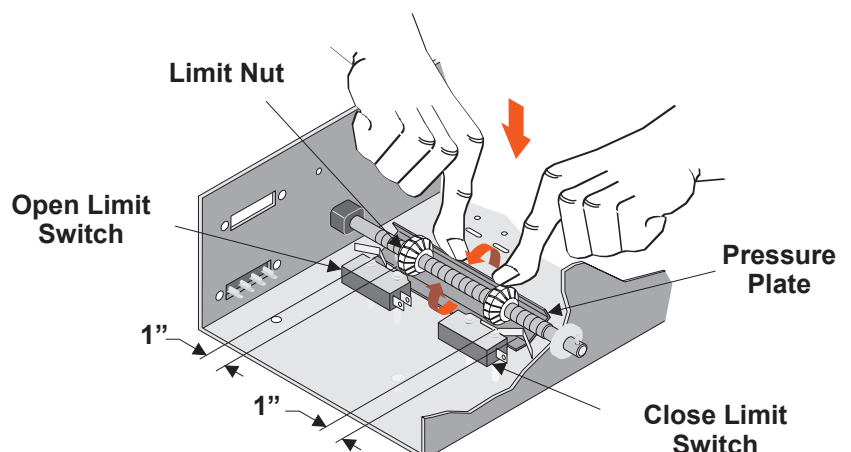

- If the limit nut depresses the open limit switch but does not stop the gate, press the stop button or turn off the power immediately and consult the factory (1-800-243-4476).

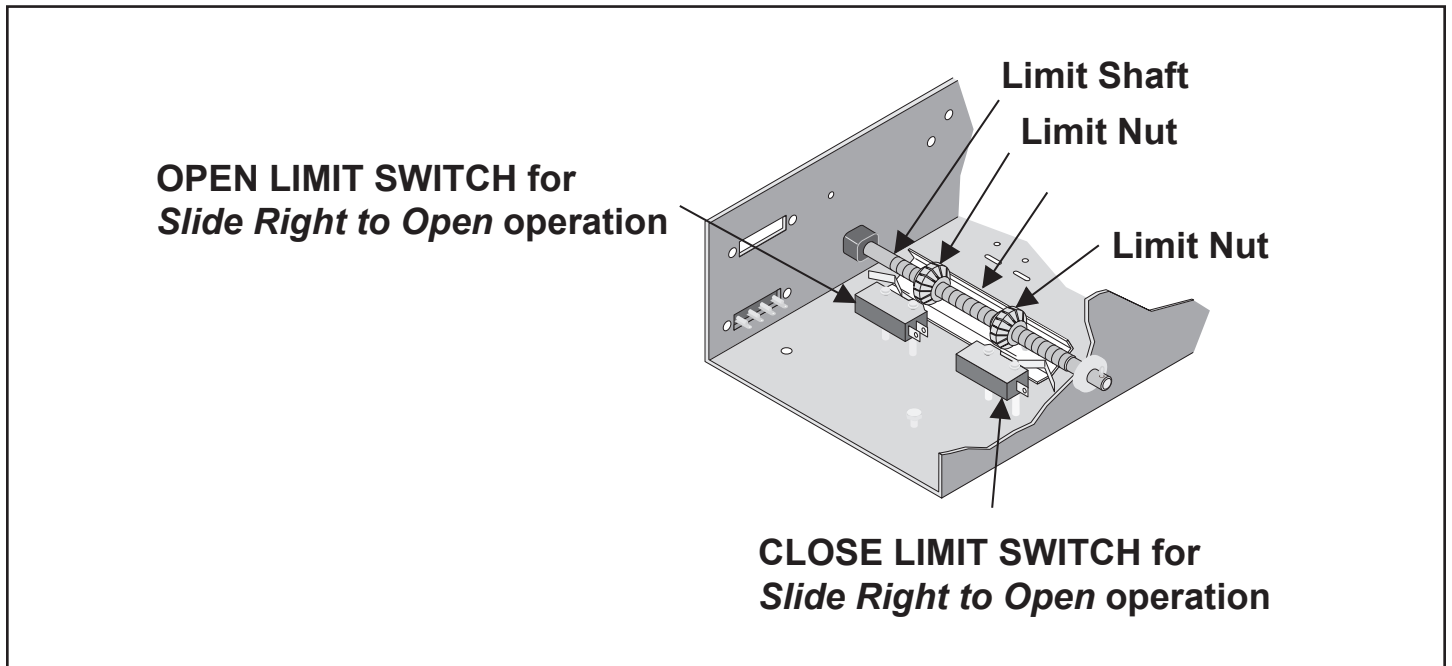

- If the operator functions properly, run the operator to the open limit switch and turn off the power.
- If there is still a distance before the gate is fully open, turn off power, move the open limit nut away from the open limit switch a few turns, and turn on the power.
- Press the *Open* button again to check how much further the gate opened. Continue this procedure until the Open Limit is set.
*When making fine adjustments, turn the limit nut 1/4 to 1/2 turn at a time. Reconnect power and test run the gate.

NOTE: Open and Close Limit Switches are reversed for *Slide Left to Open* operation.

- Repeat procedure for the *Close* limit adjustment.

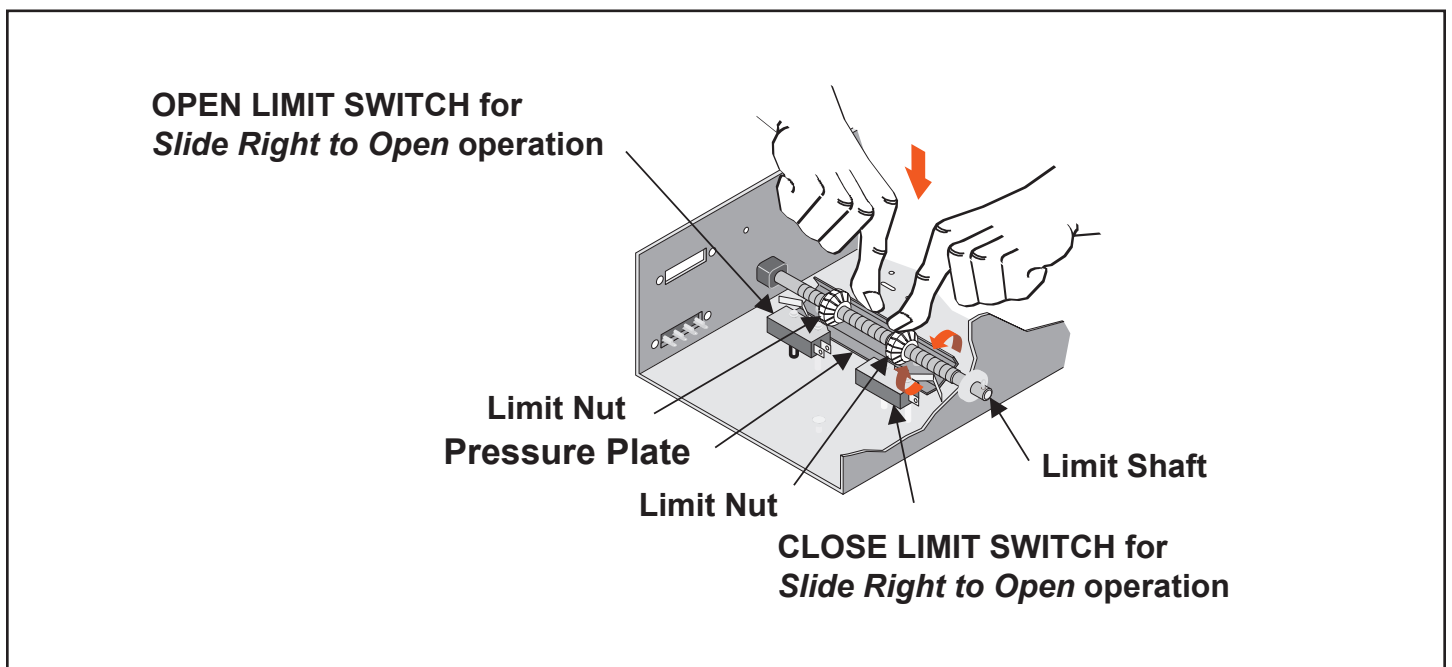

- After the desired open and close position of the gate has been obtained, make certain that a groove in both limit nuts are engaged by the pressure plate.

INSTALLATION OPTIONS

LEFT/RIGHT HAND CONVERSION

Determine the hand of the operator required for this installation by checking the direction the gate moves to open when viewed from inside the fence. If it slides *right* to open is a right hand installation. If it slides *left* to open, it is a left hand installation.

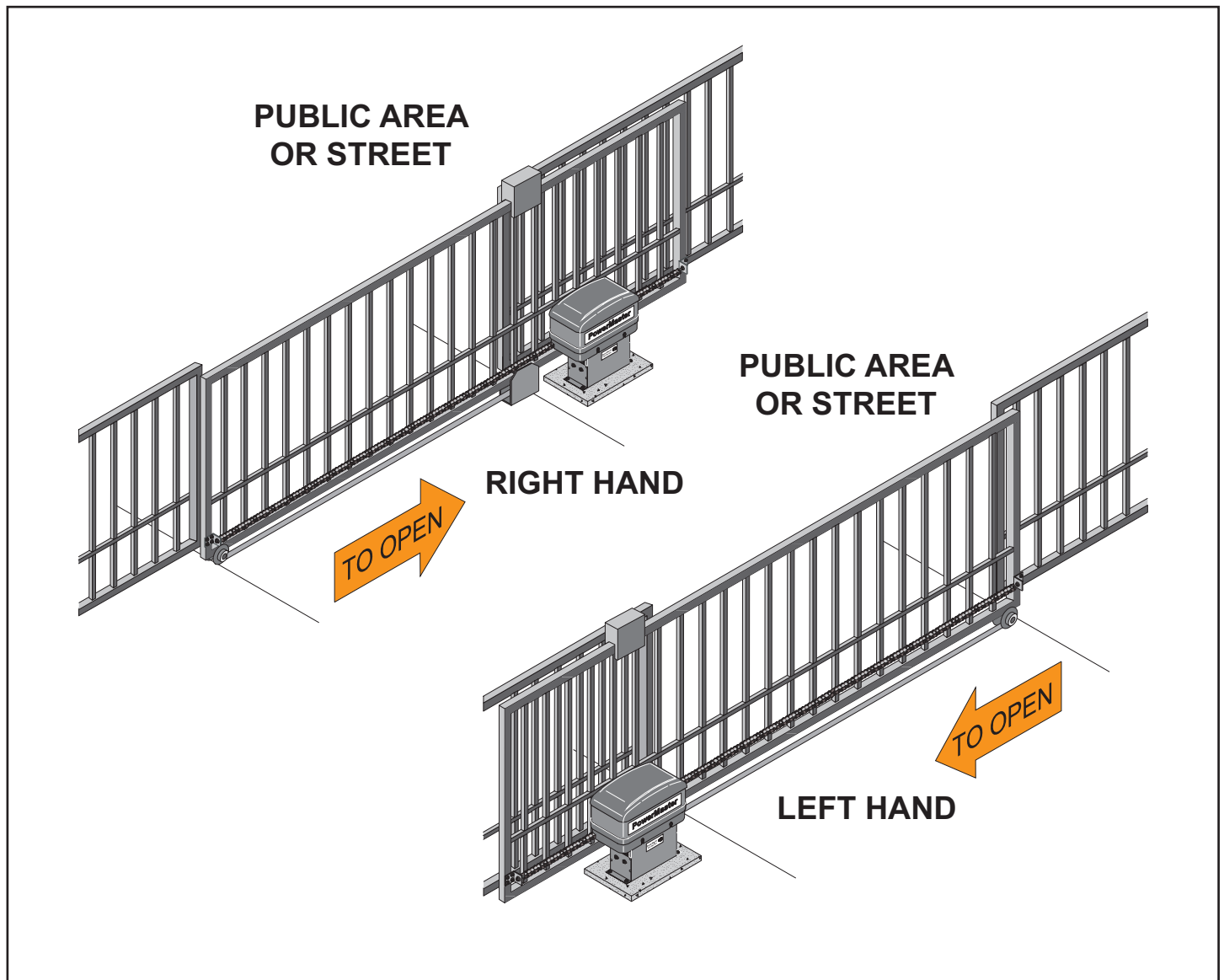

LOOP DETECTOR SYSTEMS AND INSTALLATION

Figure 8 below depicts the typical loop options for a Slide Gate installation.

1. The **Exit Loop** provides a signal to open the gate when a vehicle enters the loop zone.
2. The **Reversing Loop** protects a vehicle in the loop zone from being contacted with the gate by overriding any close signal while the gate is open, and by reversing the gate if closing.

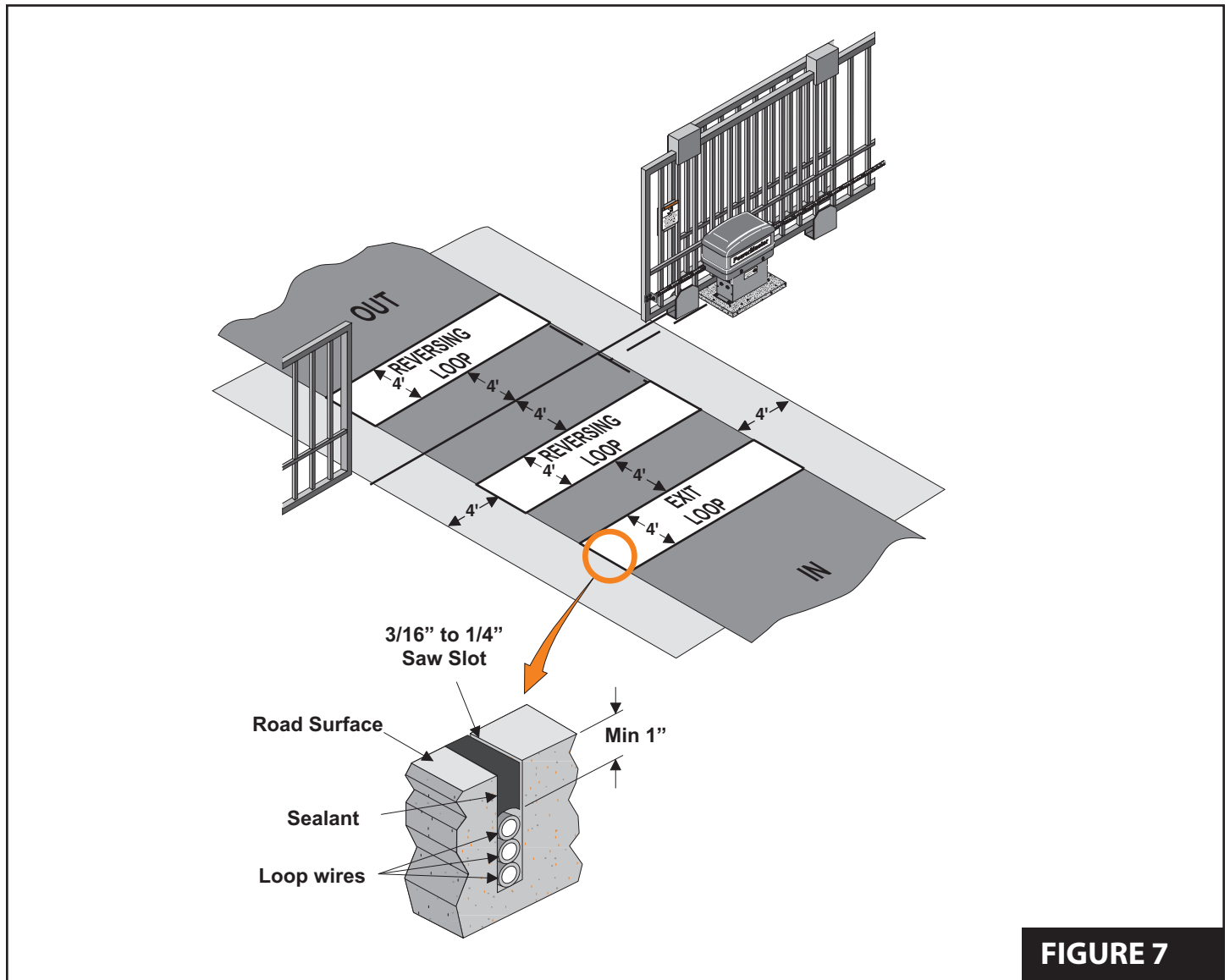

LOOP INSTALLATION

1. Lay out the desired loop locations per the diagram. The standard size chart on the following page will give an approximate length of wire required for various loop dimensions and number of turns required.

NOTE: Length of lead-in wires must be added to loop lengths for total length of wire required.

CAUTION: The loop wires and lead-in wires must be a continuous piece of wire without splices. Only use wire intended for this type of application (Type XHHW insulation 16AWG).

NOTE: Buried steel from drains or other systems may affect functioning of the loop system. Check with the factory for advice on any special installations. Call 1-800-243-4476.

STANDARD LOOP LAYOUT FOR APPROX. 36" HEIGHT DETECTION

LOOP SIZE	NUMBER OF TURNS	LOOP WIRE LENGTH
4X4	4	64
4X6	4	80
4X8	3	72
4X10	3	84
4X12	3	96
4X14	3	108
4X16	3	120
4X18	3	132
4X20	3	144
4X22	3	156
4X24	3	168
4X26	3	180
4X28	3	192
4X30	2	136
4X32	2	144
4X34	2	152
4X36	2	160
4X38	2	168
4X40	2	176

- Cut the required groove at the locations laid out in **Step#1** according to the diagram below (**Figure 9**).

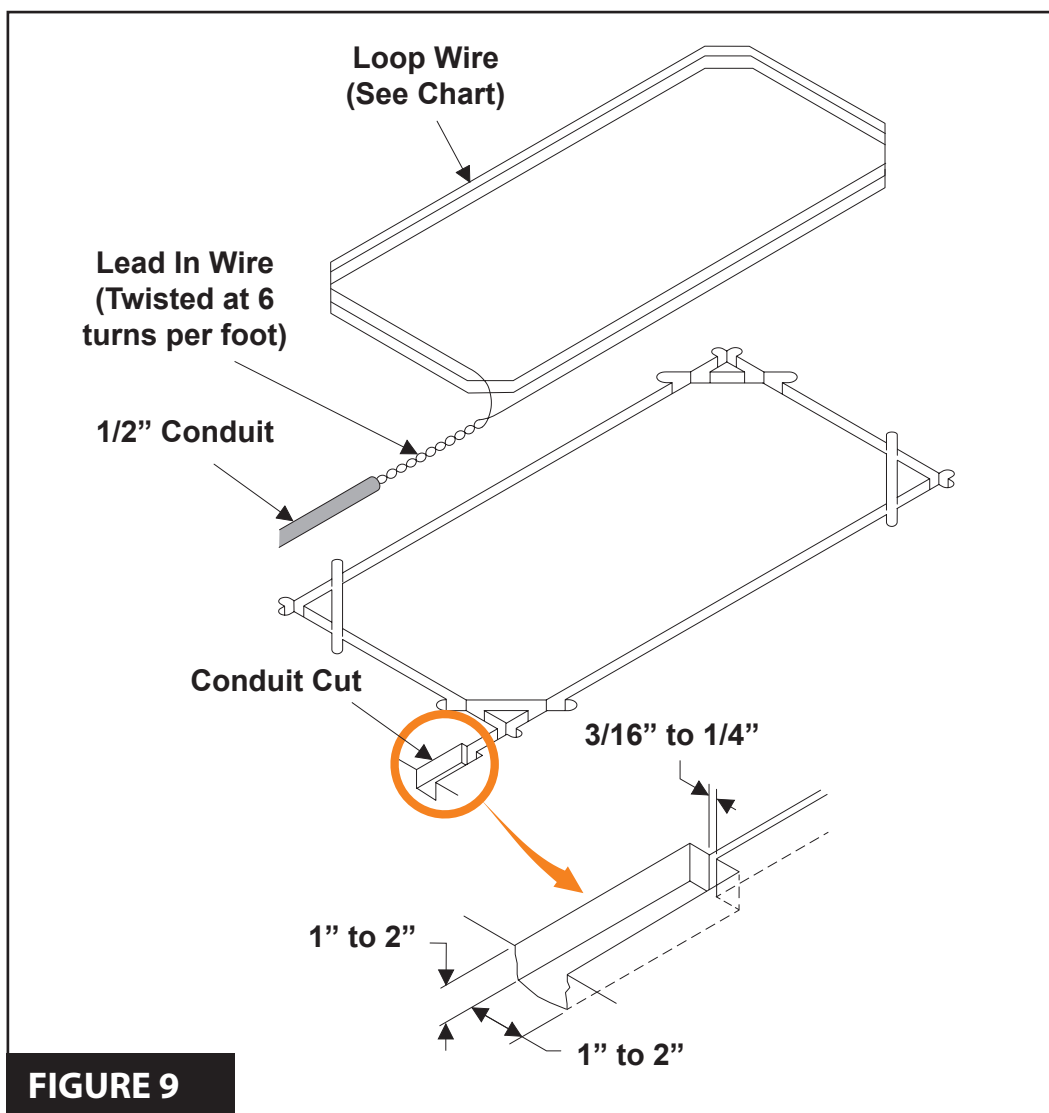

FIGURE 9

3. Leaving enough wire for the lead-in, insert the specified number of turns of wire in the cut grooves (See chart).

CAUTION: Be careful not to damage the wire insulation during installation.

4. After completing the required number of loop turns, twist the ends together at the rate of 6 turns per foot to form the lead-in.
5. Seal the lead-in wire in the conduit to prevent moisture seepage into the conduit.
6. Fill over the loop wires in the groove with a recommended loop sealant. Contact your distributor for available sealants.

SAFETY DEVICE CONNECTIONS

NON-CONTACT SENSOR INSTALLATION

1. Install photoelectric cell as close to inside of gate as possible. Photocells should be installed across the gate opening and behind the gate, at least 10 inches above ground (see **Figure 10**).

NOTE: A separate pedestrian gate must be installed if there is no other entry access but the vehicular gate.

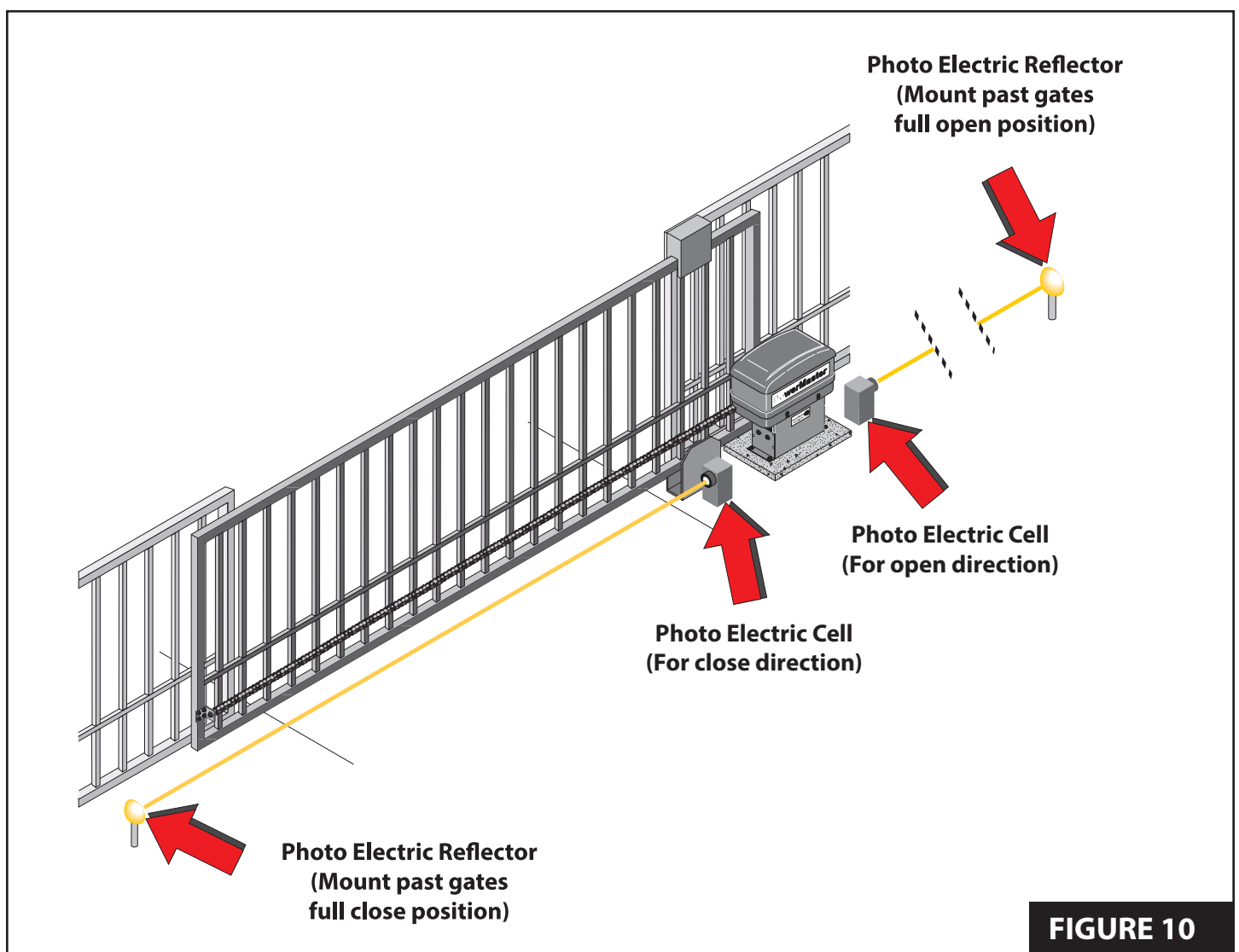

powermaster

SUPPLEMENTARY INSTRUCTION MANUAL

for units equipped with
PowerMaster Nitro Board





WARNING: These operators have been designed and constructed for use with voltages from 115 to 460 VAC. Check the operator nameplate label on the control box cover for the proper voltage and phase. The application of an improper input voltage or phase will result in catastrophic failure to the internal electrical components.

When hard wiring, observe state and local electrical codes. A wiring diagram is attached to the inside of the control box cover. Connect the appropriate voltage and phase power leads to the appropriate terminals and connect a ground wire to the grounding screw.

The wiring diagram attached inside the cover of the control box details all of the field wiring terminal connections for the operator. Always connect the wires to the push-button control and auxiliary devices exactly as shown.

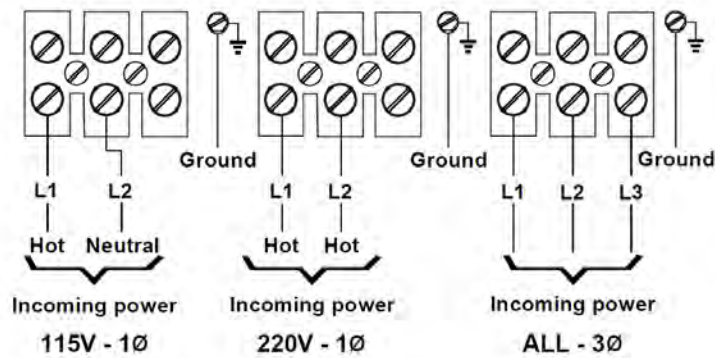

WARNING:

Control voltage of the door operator is 5 volts DC, Class 2. Do not run the power leads and control circuit wiring in the same electrical conduit.



WARNING

TO PREVENT THE RISK OF PERSONAL INJURY AND / OR DAMAGE TO DOOR OR PROPERTY, ONLY OPERATE DOOR CONTROL WHEN DOOR IS IN CLEAR VIEW. IF CONTROL STATION CANNOT BE LOCATED WHERE THE DOOR IS VISIBLE OR IF ANY OTHER DEVICE IS USED TO CONTROL THE DOOR AN AUXILIARY ENTRAPMENT DEVICE SUCH AS A DOOR EDGE OR PHOTOELECTRIC MUST BE CONNECTED.

Note: These Operators are able to accept monitored safety devices for entrapment protection. To comply with code requirements, at least one monitored safety device **MUST** be installed and wired to the operator. Additional safety devices may be necessary, depending on installation requirements.

Number 22-gauge wire or heavier must be used for wiring the control stations and auxiliary control devices to the operator. Smaller gauge wire may cause operational problems.



WARNING

TO AVOID POSSIBLE DAMAGE TO THE DOOR AND OPERATOR ENSURE ALL DOOR LOCKS ARE DISABLED. SETUP THE LOCKBAR SENSING ON THE CONTROL BOARD, OR USE AN INTERLOCK SWITCH IF A LOCK IS REQUIRED TO RETAIN FUNCTIONALITY.

Contents

1	Board Interface	5
2	Headers	6
3	Terminals	7
4	Setup Wizard	8
5	Status	11
6	Menu Overview	11
7	Basic Programming	11
8	Advanced Programming	15
9	About	19
10	Lockout	22

1 Board Interface

LCD Navigation

The board is equipped with **UP**, **DOWN**, **BACK**, and **ENTER** buttons located to the upper right corner of the board.

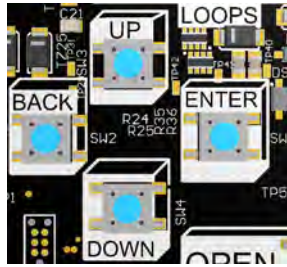

On Board 3-Button Controls

The board is equipped with **OPEN**, **CLOSE**, and **STOP** buttons located to the right side of the board.

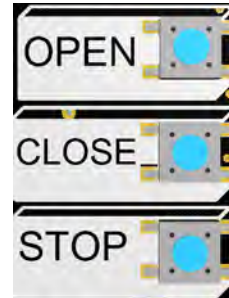

LCD Display

The board is equipped with a 20 x 4 LCD display to provide user feedback and change settings.



Contrast Adjustment

The board is equipped with a potentiometer in order to adjust the contrast of the LCD screen.

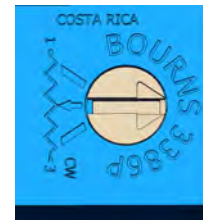

2 Headers

Encoder

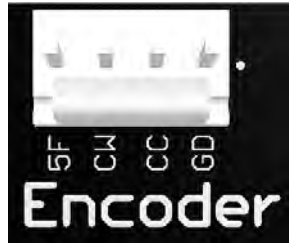

Limits



Expansion Headers

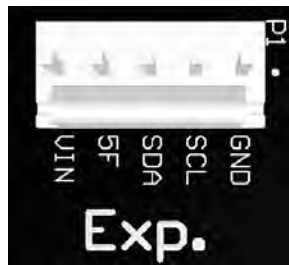

3 Wire Header



DC Motor Header



AC Motor Header



Expansion Module Header

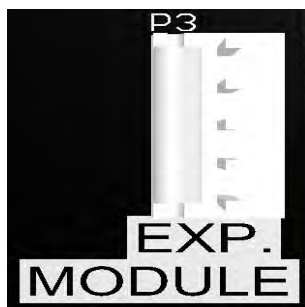

Radio Header



3 Terminals

Horn Terminal



Brake Terminal



Power Terminal

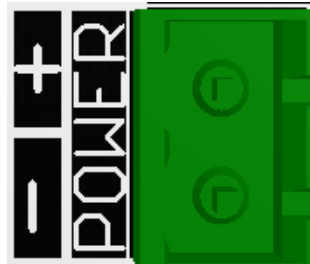

24 VDC

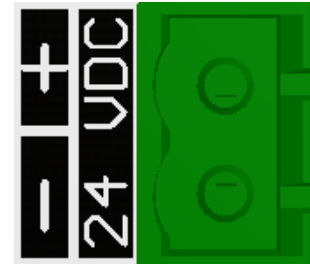

Terminal Strip



4 Setup Wizard

Setup Introduction

1. To begin setting up the operator press the **ENTER** button.

```
****SETUP WIZARD****  
PRESS ENTER
```

Operator Type

1. To select the correct operator type press the **UP** and **DOWN** buttons.

2. Once the desired operator type is selected press the **ENTER** button.

```
**OPERATOR SELECT**  
> SLIDE GATE  
  SWING GATE  
  BARRIER GATE
```

Operator Select

1. To select the correct operator press the **UP** and **DOWN** buttons.

2. Once the desired operator is selected press the **ENTER** button.

```
*****SLIDE GATE*****  
> AC MOTOR  
  DC MOTOR  
  VARIABLE SPEED
```

```
*****SWING GATE*****  
> AC MOTOR  
  DC MOTOR  
  VARIABLE SPEED
```

NOTE: The model of the operator can be found on the cover or side of the machine.

Handedness

1. To select the correct hand press the **UP** and **DOWN** buttons.
2. Once the desired hand is selected press the **ENTER** button.



```
*****HANDING*****  
> RIGHT HAND  
LEFT HAND
```

NOTE: The hand of the operator is the side of the driveway the operator is on from the inside looking out.

Open Force Setup

1. Hold the **OPEN** button and run the operator from the **FULLY CLOSED** position all the way to the **OPEN LIMIT**.
2. Once the operator is at the **FULLY OPEN** position press the **ENTER** button.

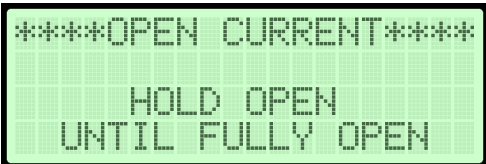

```
****OPEN CURRENT****  
HOLD OPEN  
UNTIL FULLY OPEN
```

NOTE: The open current setting adjusts the maximum current allowed to operate the door/gate in the open direction.

If the open current load exceeds this threshold, the operator will trigger a safety.

Close Force Setup

1. By holding the **CLOSE** button run the operator from the **FULLY OPEN** position all the way to the **CLOSE LIMIT**.

2. Once the operator is at the **FULLY CLOSED** position press the **ENTER** button.

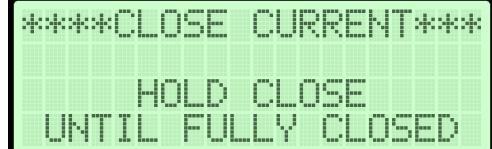

```
****CLOSE CURRENT****  
HOLD CLOSE  
UNTIL FULLY CLOSED
```

NOTE: The close current setting adjusts the maximum current allowed to operate the door/gate in the close direction.

If the close current load exceeds this threshold, the operator will trigger a safety.

Auto Close Time Adjustment

1. By pressing the **UP** and **DOWN** buttons set the adjusted time for the auto close timer.

2. Once the desired time is set press the **ENTER** button.

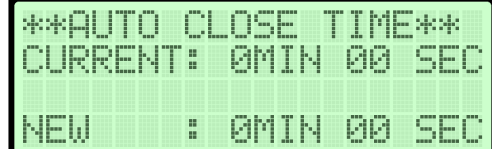

```
**AUTO CLOSE TIME**  
CURRENT: 0MIN 00 SEC  
NEW : 0MIN 00 SEC
```

NOTE: 0 MIN 00 SEC is OFF. The Auto Close Time specifies the time it will take until a gate or door automatically closes after it has been opened.

5 Status

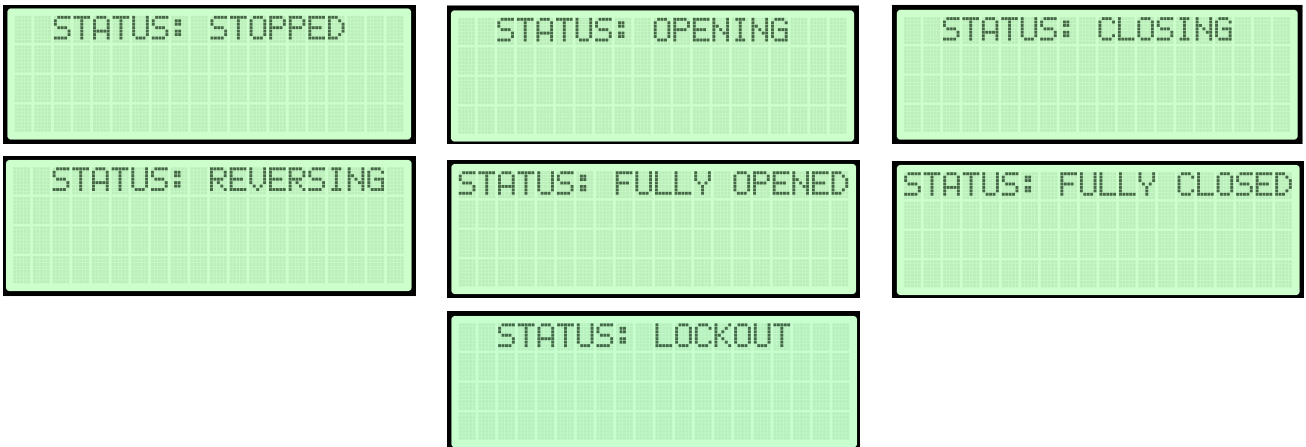

6 Menu Overview

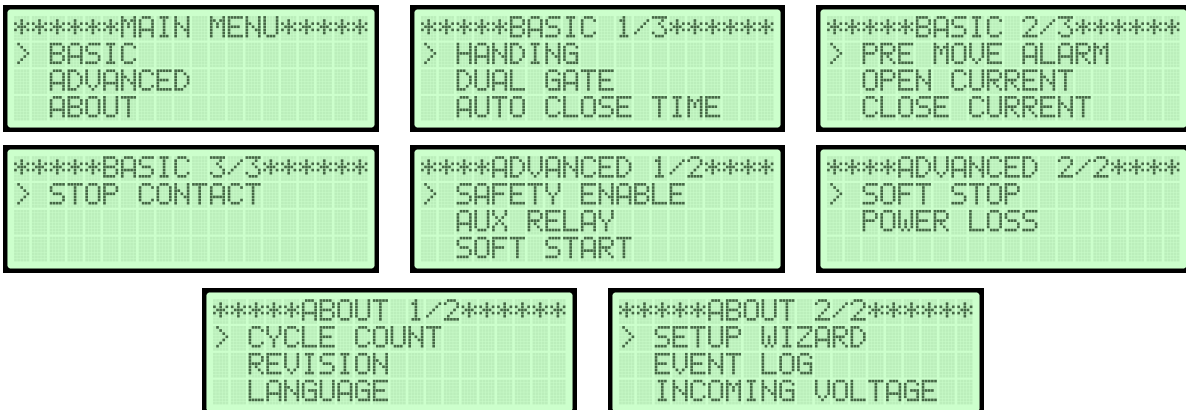

7 Basic Programming

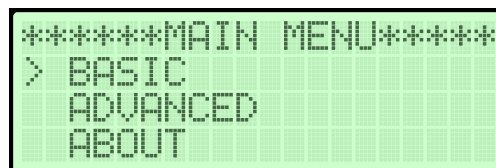

Handing

1. When the pointer is at **HANDING** press the **ENTER** button.
2. To select the correct hand press the **UP** and **DOWN** buttons.
3. Once the desired hand is selected press the **ENTER** button.

```
*****BASIC 1/3*****  
> HANDING  
  DUAL GATE  
  AUTO CLOSE TIME
```

```
*****HANDING*****  
> RIGHT HAND *  
  LEFT HAND
```

NOTE: The hand of the operator is the side of the driveway the operator is on from the inside looking out.

Dual Gate

1. When the pointer is at **DUAL GATE** press the **ENTER** button.
2. Once the desired gate is selected press the **ENTER** button.

```
*****BASIC 1/3*****  
  HANDING  
> DUAL GATE  
  AUTO CLOSE TIME
```

```
*****DUAL GATE*****  
> SINGLE GATE *  
  DUAL GATE
```

NOTE: The single gate setting is for standalone gates. The dual gate setting is for gates that run simultaneously.

Auto Close Time

1. When the pointer is at **AUTO CLOSE TIME** press the **ENTER** button.
2. By pressing the **UP** and **DOWN** buttons set the adjusted time for the auto close timer.
3. Once the desired time is set press the **ENTER** button.

```
*****BASIC 1/3*****  
HANDING  
DUAL GATE  
> AUTO CLOSE TIME
```

```
**AUTO CLOSE TIME**  
CURRENT: 0MIN 00 SEC  
NEW      : 0MIN 00 SEC
```

NOTE: 0 MIN 00 SEC is OFF. The auto close time specifies the time it will take until a gate or door automatically closes after it has triggered the open limit.

Pre Move Alarm

1. When the pointer is at **PRE MOVE ALARM** press the **ENTER** button.
2. By pressing the **UP** and **DOWN** buttons set the adjusted time for the pre move alarm.
3. Once the desired time is set press the **ENTER** button.

```
*****BASIC 2/3*****  
> PRE MOVE ALARM  
OPEN CURRENT  
CLOSE CURRENT
```

```
**PRE MOVE ALARM**  
CURRENT: 0 SEC  
NEW      : 0 SEC
```

NOTE: 0 SECONDS is OFF. The pre move alarm allows users to specify the amount of time a door or gate should wait until opening/closing.

Open Current

1. When the pointer is at **OPEN CURRENT** press the **ENTER** button.
2. By pressing the **UP** and **DOWN** buttons set the maximum current for the open current setting.
3. Once the desired current is set press the **ENTER** button.

```
*****BASIC 2/3*****  
PRE MOVE ALARM  
> OPEN CURRENT  
CLOSE CURRENT
```

```
*****OPEN CURRENT*****  
CURRENT: 5  
NEW : 5
```

NOTE: The open current setting adjusts the maximum current allowed to operate the door/gate in the open direction. If the open current load exceeds this threshold, the operator will trigger a safety.

Close Current

1. When the pointer is at **CLOSE CURRENT** press the **ENTER** button.
2. By pressing the **UP** and **DOWN** buttons set the maximum current for the close current setting.
3. Once the desired current is set press the **ENTER** button.

```
*****BASIC 2/3*****  
PRE MOVE ALARM  
OPEN CURRENT  
> CLOSE CURRENT
```

```
*****CLOSE CURRENT***  
CURRENT: 5  
NEW : 5
```

NOTE: The close current setting adjusts the maximum current allowed to operate the door/gate in the close direction. If the close current load exceeds this threshold, the operator will trigger a safety.

Stop Contact

1. When the pointer is at **STOP CONTACT** press the **ENTER** button.
2. By pressing the **UP** and **DOWN** buttons set Normally Open or Normally Close.
3. Once the desired contact is set press the **ENTER** button.

```
*****BASIC 3/3*****  
> STOP CONTACT
```

```
*****STOP CONTACT*****  
> NORMALLY CLOSED *  
NORMALLY OPEN
```

NOTE: Stop Contact set's whether the STOP contact is Normally Open or Normally Close.

8 Advanced Programming

```
*****MAIN MENU*****  
BASIC  
> ADVANCED  
ABOUT
```

Safety Enable

1. When the pointer is at **SAFETY ENABLE** press the **ENTER** button.
2. Users will be allowed to select between **CLOSE SAFETY** and **OPEN SAFETY**.

```
*****ADVANCED 1/2*****  
> SAFETY ENABLE  
AUX RELAY  
SOFT START
```

```
***SAFETY ENABLE***  
> CLOSE SAFETY 2  
OPEN SAFETY 2
```

Close Safety

1. When the pointer is at **CLOSE SAFETY** press the **ENTER** button.
2. By pressing the **UP** and **DOWN** buttons select the desired setting.
3. Once the desired setting is selected press the **ENTER** button.

```
***SAFETY ENABLE***  
> CLOSE SAFETY 2  
OPEN SAFETY 2
```

```
***CLOSE SAFETY 2*  
> ON  
OFF*
```

NOTE: Close safety will detect an obstruction during closing while the gate is moving. Any close obstruction signal will cause the gate to stop then reverse to the full open position.

Open Safety

1. When the pointer is at **OPEN SAFETY** press the **ENTER** button.
2. By pressing the **UP** and **DOWN** buttons select the desired setting.
3. Once the desired setting is selected press the **ENTER** button.

```
***SAFETY ENABLE***  
CLOSE SAFETY 2  
> OPEN SAFETY 2
```

```
***OPEN SAFETY 2**  
> ON  
OFF*
```

NOTE: Open safety will detect an obstruction during opening while the gate is moving. Any open obstruction signal will cause the gate to stop then reverse to the full closed position.

Aux Relay

1. When the pointer is at **AUX RELAY** press the **ENTER** button.
2. By pressing the **UP** and **DOWN** buttons select the desired setting.
3. Once the desired setting is selected press the **ENTER** button.

```
****ADVANCED 1/2****  
SAFETY ENABLE  
> AUX RELAY  
SOFT START
```

```
*****AUX RELAY*****  
> AUX RELAY OFF *  
MAGLOCK  
STROBE
```

- Aux Relay Off: the auxiliary relay will be disabled
 - Maglock: the magnetic gate lock will be enabled during pending or actual motion (open/close)
 - Strobe: the warning strobe light will be enabled during pending or actual motion (open/close)
-

Soft Start

1. When the pointer is at **SOFT START** press the **ENTER** button.
2. By pressing the **UP** and **DOWN** buttons select the desired setting.
3. Once the desired setting is selected press the **ENTER** button.

```
****ADVANCED 1/2****  
SAFETY ENABLE  
AUX RELAY  
> SOFT START
```

```
*****SOFT START*****  
CURRENT: 0  
NEW : 0
```

NOTE: The soft start feature will cause the operator to start the DC motor slowly. This reduces gate malfunctions from wear and tear as well as an overload of current. It is recommended for gates with heavy loads.

Soft Stop

1. When the pointer is at **SOFT STOP** press the **ENTER** button.
2. By pressing the **UP** and **DOWN** buttons select the desired setting.
3. Once the desired setting is selected press the **ENTER** button.

```
*****ADVANCED 2/2*****  
> SOFT STOP  
POWER LOSS
```

```
*****SOFT STOP*****  
CURRENT: 0  
NEW      : 0
```

NOTE: The soft stop feature will cause the operator to stop the DC motor slowly. This reduces gate malfunctions from wear and tear as well as an overload of current. It is recommended for gates with heavy loads.

Stop Contact

1. When the pointer is at **POWER LOSS** press the **ENTER** button.
2. By pressing the **UP** and **DOWN** buttons select the desired setting.
3. Once the desired setting is selected press the **ENTER** button.

```
*****ADVANCED 2/2*****  
SOFT STOP  
> POWER LOSS
```

```
*****POWER LOSS*****  
> FAIL SAFE *  
FAIL SECURE
```

NOTE: Select Fail Safe if the intended operation when the batteries are low that the operator will go to the full OPEN position. Select Fail Secure if the intended operation when the batteries are low that the operator will go to the full CLOSE position.

9 About

```
*****MAIN MENU*****  
  BASIC  
  ADVANCED  
> ABOUT
```

Cycle Count

1. When the pointer is at **CYCLE COUNT** press the **ENTER** button.
2. The cycle count will then be displayed.

```
*****ABOUT 1/2*****  
> CYCLE COUNT  
  REVISION  
  LANGUAGE
```

```
*****CYCLE COUNT*****  
CYCLE COUNT: 123456
```

NOTE: The cycle count shows the number of cycles the operator has run for. 1 cycle is considered a full open and close motion.

Revision

1. When the pointer is at **REVISION** press the **ENTER** button.
2. The revision number will then be displayed.

```
*****ABOUT 1/2*****  
  CYCLE COUNT  
> REVISION  
  LANGUAGE
```

```
*****REVISION*****  
> U1.01
```

Language

1. When the pointer is at **LANGUAGE** press the **ENTER** button.
2. By pressing the **UP** and **DOWN** buttons select the desired setting.
3. Once the desired setting is selected press the **ENTER** button.

```
*****ABOUT 1/2*****  
CYCLE COUNT  
REVISION  
> LANGUAGE
```

```
*****LANGUAGE*****  
> ENGLISH *  
SPANISH
```

NOTE: This setting allows the user to change the language for the LCD. Currently English and Spanish are supported.

Event Log

1. When the pointer is at **EVENT LOG** press the **ENTER** button.
2. By pressing the **UP** and **DOWN** buttons, you can view the logs.

```
*****ABOUT 2/2*****  
SETUP WIZARD  
> EVENT LOG  
INCOMING VOLTAGE
```

```
***EVENT LOG 1/5***  
1. STOP  
2. OPENING  
3. OPEN BUTTON
```

NOTE: A log of the 15 most recent activities will be shown. The most recent activity will be number "1".

Setup Wizard

1. When the pointer is at **SETUP WIZARD** press the **ENTER** button.

```
*****ABOUT 2/2*****  
> SETUP WIZARD  
EVENT LOG  
INCOMING VOLTAGE
```

2. By pressing the **ENTER** button, the setup wizard will run.

```
****SETUP WIZARD****  
PRESS ENTER
```

Incoming Voltage

1. When the pointer is at **Incoming Voltage** press the **ENTER** button.

```
*****ABOUT 2/2*****  
SETUP WIZARD  
EVENT LOG  
> INCOMING VOLTAGE
```

2. This will display what voltage is being supplied to the circuit board in real time.

```
**INCOMING VOLTAGE**  
VOLTAGE : 31.7 UDC
```

10 Lockout

Low Voltage:

Reason: This lockout occurs when the total voltage of the system is below 21.5 volts.

Fix: Restore voltage to above 21.5 volts.

- Make sure that no fuses are blown and that there is adequate AC power.
- This will occur when batteries are fully discharged after AC power loss. Batteries will recharge when AC power is restored.

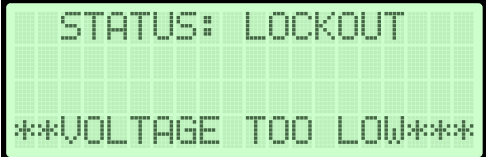

```
STATUS: LOCKOUT
**VOLTAGE TOO LOW**
```

Two Safeties Tripped:

Reason: This lockout occurs when a total of two safety reversals happen before a limit is triggered. This can be any combination of external safeties or the inherent force limiter.

Fix: Press the **STOP** button on the circuit board.

- Check external safety devices.
- Check that the gate moves freely.
- Re-adjust the force settings on the board.
- Check log for greater details.



```
STATUS: LOCKOUT
TWO SAFETIES TRIPPED
```

Motor Not Detected:

Reason: This lockout occurs when the circuit board does not detect a that a motor is present.

Fix: Press the **STOP** button on the circuit board.

- Check that the motor overload isn't tripped.
 - Check the motor wiring is correct and not damaged.
 - Check that the motor brushes aren't damaged or worn out.
-

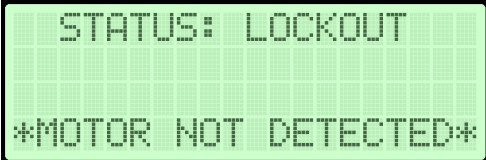

```
STATUS: LOCKOUT
*MOTOR NOT DETECTED*
```

Terminal Characteristics

#	Terminal	Voltage	Description
1	GND	0 VDC	Ground connection
2	OPEN	24-30 VAC	Open command. This is a NO connection.
3	CLOSE	24-30 VAC	Close command. This is a NO connection.
4	STOP	5 VDC	Stop command. Can be configured NO or NC
5	AUX OPEN	5 VDC	Auxiliary open command. Serves as open command for devices other than push button. This is a NO connection.
7	FIRE	5 VDC	NO connection in fire box for fire department access
8	SINGLE	30 VDC	NO connection to alternate between open and close with single button operation.
10	AUX	5-30 VDC	Connects to auxiliary devices
11	REV	5 VDC	NO connection to device. Causes reversal in direction
13	SHADOW	5 VDC	Keeps the gate open as long as the signal is present. This is a NO connection.
14	CLOSE SAFETY 1	5 VDC	Required pulse or 10k monitored safety device. This terminal monitors when the gate is CLOSING
16	CLOSE SAFETY 2	5-30 VDC	Optional pulse or 10k monitored safety device. This terminal monitors when the gate is CLOSING
17	OPEN SAFETY 1	5-30 VDC	Required pulse or 10k monitored safety device. This terminal monitors when the gate is OPENING
19	OPEN SAFETY 2	5-30 VDC	Optional pulse or 10k monitored safety device. This terminal monitors when the gate is OPENING
20	AUX RELAY N.C	0-120 VAC	NC connection for auxiliary relay.
21	AUX RELAY COM	0-120 VAC	COM connection for auxiliary relay.
22	AUX RELAY N.O	0-120 VAC	NO connection for auxiliary relay.
23	DUAL GATE A	5-30 VDC	Optional connection A for dual gate operation
24	DUAL GATE GND	5-30 VDC	Optional connection GND for dual gate operation.
25	DUAL GATE B	5-30 VDC	Optional connection B for dual gate operation.
26	BRK	24 VDC	Connection for an external brake
27	POWER	24-30 VAC/DC	Incoming power connection. Could be supplied off of transformer or DC power supply.
28	24 VDC	24 VDC	24 volts for accessory power connections.
29	HORN	24 VDC	Connection for the exterior horn.

PowerMaster

Limited 5-Year Warranty

PowerMaster warrants all GATE OPERATORS (Swing, Slide, Barrier categories) to be free of defects in materials and workmanship for a period of five (5) years from date of manufacture, provided that product has been registered. A one year warranty applies if product has not been registered.

ELECTRICAL PARTS (including boards, switches, relays, etc):

PowerMaster warrants electrical parts for a two (2) year period, provided that product has been registered. A one year warranty applies if product has not been registered.

If any part is found to be defective during this period, new parts will be furnished free of charge. Failure of this product due to misuse, improper installation, alterations, vandalism, acts of God, or lack of maintenance is **not** covered under this warranty, and voids any other implied warranties herein.

PowerMaster is **not responsible** for any labor charges incurred in connection with the installation of warranted parts.

In order to activate this warranty, the registration form found with your operator **MUST BE COMPLETED AND RETURNED WITHIN THIRTY CALENDAR DAYS FROM DATE OF PURCHASE**. Visit our website at www.VEpower.net and click on the **Register your Product** link.

You can also register via email to PMtech@optonline.net.

If registration is not activated, a **ONE YEAR** warranty from date of manufacture will apply for all claims.

REGISTRATION INFORMATION

Operator Information

Model SG or D-SG (Circle one)

Serial # _____

Date Installed _____

Location Installed

Address _____

Address _____

Address _____

Installer's Information

Company Name _____

Address _____

Address 2 _____

City, State, Zip _____

Telephone # _____

Contact Name _____

The end user should retain this information for their records and to obtain warranty service.

Need Technical Support?

Visit: www.PowerMasterNY.com/technical-information

Call us toll free @ 1-800-243-4476

Email us: PMtech@PowerMasterNY.com



[/PowerMasterOperators](#)



[/PowerMaster](#)



[/company/PowerMaster](#)



Scan **QR Code**
with your Smart
phone to **find us**
on the web!

www.PowerMasterNY.com

The logo for PowerMaster, featuring the word 'power' in a lowercase, outlined font with a gear icon integrated into the letter 'o', followed by 'master' in a bold, lowercase sans-serif font. Below the logo, the text 'MANUFACTURED BY V.E. POWER DOOR CO, INC.' is written in a smaller, all-caps sans-serif font.
powermaster
MANUFACTURED BY V.E. POWER DOOR CO, INC.